



# **SOLAR COLLECTORS**

## **INSTALLATION MANUAL**



**MODELS: ECO S150 – S200 – S230 – S260**



| <b>INDEX</b>   | <b>PAGE</b> |
|--|-------------|
| 1. Presentation .....  | 4           |
| 2. Parts Included .....  | 4           |
| 2.1. Solar Collectors .....  | 4           |
| 2.2. Support Frame .....   | 6           |
| 2.3. Connectors .....  | 7           |
| 3. Placement of the Collectors .....   | 8           |
| 4. Bank of Collectors .....  | 9           |
| 5. Flat Roof Installation .....  | 13          |
| 5.1. Installation of longitudinal profiles D3 and Z angle E1/E2 .....        | 13          |
| 5.2 Installation of vertical legs A3 and the long cross pieces X1/1/X2 ..... | 14          |
| 5.3. Installation of vertical legs A3 and the longitudinal profiles D3 ..... | 15          |
| 5.4. Placement of Solar Collectors .....                                     | 16          |
| 6. Tile roof installation .....  | 17          |
| 7. Connections and Hydraulic Circuit .....                                   | 17          |
| 8. Lightning Protection.....   | 20          |
| 9. Permissible wind and snow load .....                                      | 20          |
| 10. Care and Maintenance Program .....                                       | 21          |

## 1. Presentation

The present document demonstrates detailed installation instructions for the solar collectors using the support frames and accessories included in the supply.

Before proceeding with the installation of the collectors, read these instructions and make sure you have understood. If you have questions about the materials or on the assembly process described in this document, contact your supplier via telephone, fax or e-mail. Improper installation of the collectors may cause an unsatisfactory operation of the solar system, compromising its durability and even be dangerous for the people or the goods.

The instructions of this document do not exempt in any way the compliance with existing regulations and provisions of technical and administrative application at the place where the facility is located.

The installation of solar collectors without following the instructions in this document and / or regulations will invalidate the warranty of the product.

The installer will check before starting the installation that he has all the necessary parts and all the security measures have been taken in order to carry out the installation safely. The installer must use protective gloves to avoid any risk of burns or cuts during handling of collectors or its support frame.

## 2. Parts Included

The supply consists of:

One or more solar collectors

One or more support frames

Two or more fitting and connection (except for a single collector)

### 2.1. Solar Collectors

The solar collectors are supplied individually packaged in carton boxes. The collector model is indicated on the outside of each box. Depending on the number of units ordered, collectors can be supplied palletised in groups of up to 10 units. Collectors should always be during transport and storage placed with the glass facing on top, otherwise there is danger of water entering in the collectors from the ventilation holes at the back of the collector.

The main technical characteristics of the collectors are indicated below (figure no. 1)

| TYPE | WEIGHT  | DIMENSIONS (mm) |      |      |     |      |      |
|------|---------|-----------------|------|------|-----|------|------|
|      |         | A               | B    | C    | D   | E    | F    |
| S150 | 24,00kg | 960             | 1540 | 1010 | 895 | 1458 | 1815 |
| S200 | 29.50kg | 960             | 1960 | 1010 | 895 | 1878 | 2183 |
| S230 | 35,50kg | 1165            | 1960 | 1215 | 895 | 1878 | 2280 |
| S260 | 40,00kg | 1238            | 2135 | 1308 | 895 | 2055 | 2468 |

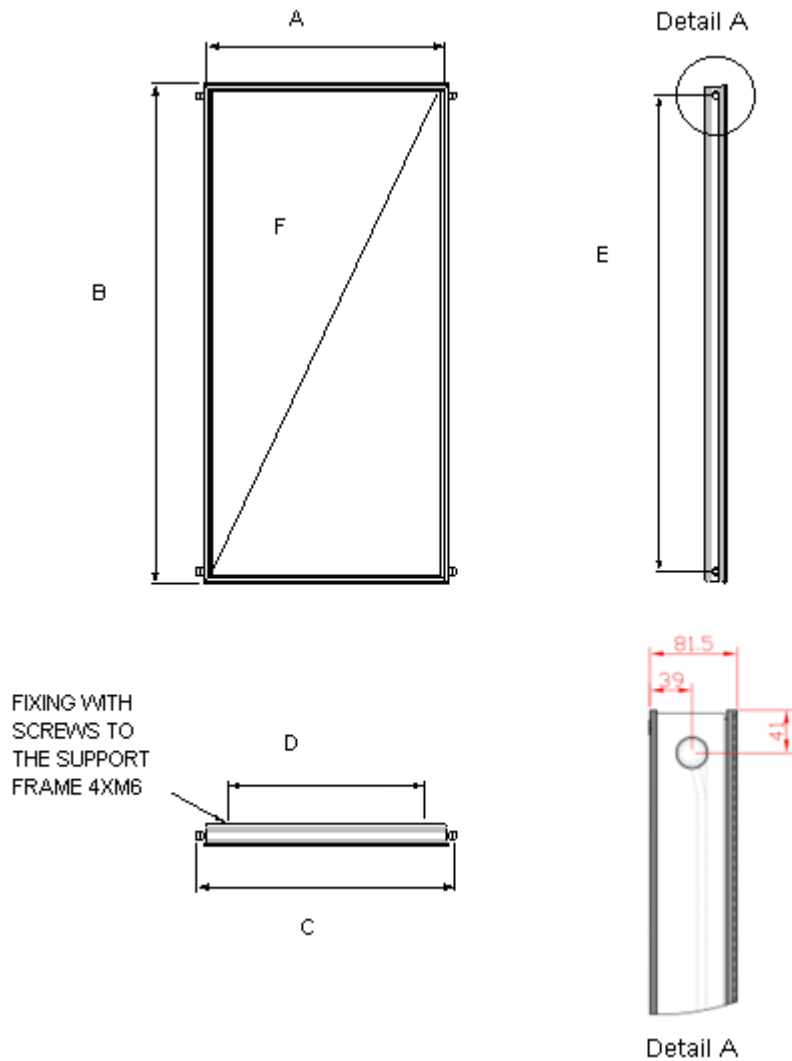

|                          |   |
|--------------------------|---|
| <b>Absorber</b>          | Copper tubes and aluminium fins with selective coating.             |
| <b>Pressure test</b>     | 15 bar  |
| <b>Pressure max.</b>     | 10 bar  |
| <b>Isolation</b>         | Side: 20 mm glass wool<br>back: 40 mm rock wool                     |
| <b>Casing</b>            | Aluminium profile Free of bolts and rivets.<br>Sea Water resistant. |
| <b>Glass</b>             | Tempered low iron prismatic glass 3.2 mm.                           |
| <b>Sealing</b>           | Structural Glazing Silicon Sealant                                  |
| <b>Connector</b>         | Compression union 18x18   |
| <b>Flow recommended</b>  | 40 litres/h/m <sup>2</sup>  |
| <b>Content of liquid</b> | S150 = 0,85ltr; S200 = 0,95 ltr; S230 = 1,20ltr; S260 = 1,30ltr     |

Figure 1. Characteristics of solar collector

The manufacturing of the solar collector follow strict quality criteria and is certified by ISO 9001:2008.

## 2.2. Support Frame

There are two sets of support frames for a single collector (EST1) or for two collectors (EST2).

Depending on the bank of solar collectors chosen, the appropriate number of support frames will be provided for one or two collectors. Table 1 shows the sets of support frames necessary for different banks of solar collectors.

| N° of collectors in bank | 1 | 2 | 3 | 4 | 5 | 6  |
|--------------------------|---|---|---|---|---|----|
| EST1                     | 1 | - | 1 | - | 1 | -  |
| EST2                     | - | 1 | 1 | 2 | 2 | 3  |
| Connectors               | - | 2 | 4 | 6 | 8 | 10 |

Table 1. The support frames and the connections provided depend on the number of collectors per bank

The support frames sets are composed of elements that are shown in Figures 3 and 4.

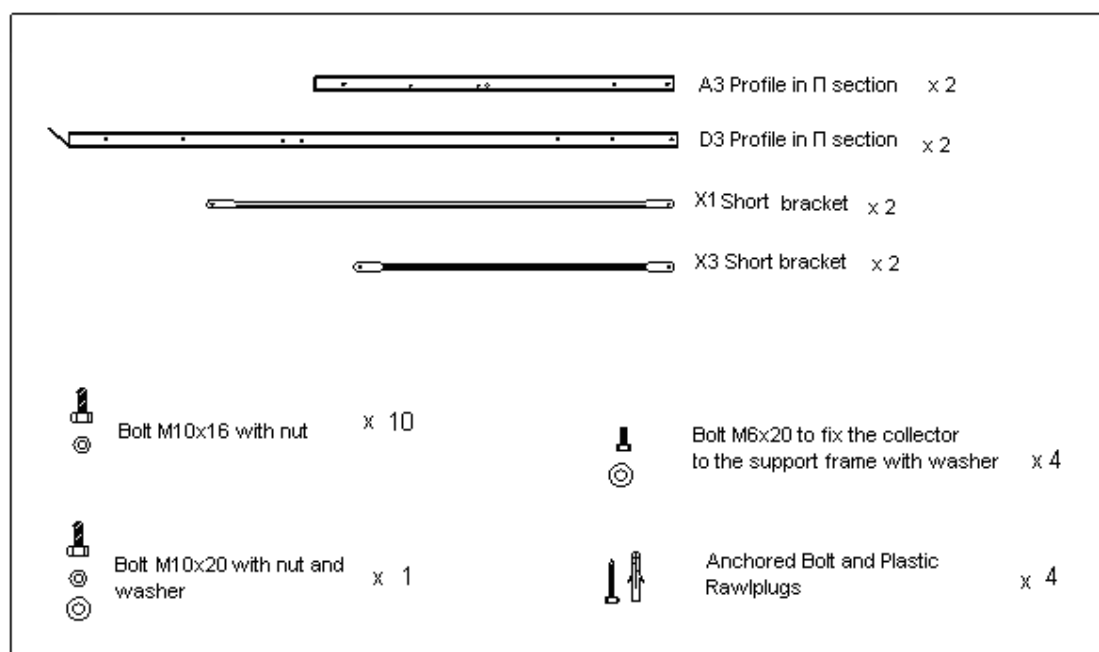

Figure 3. Support frame components EST1 for a single solar collector

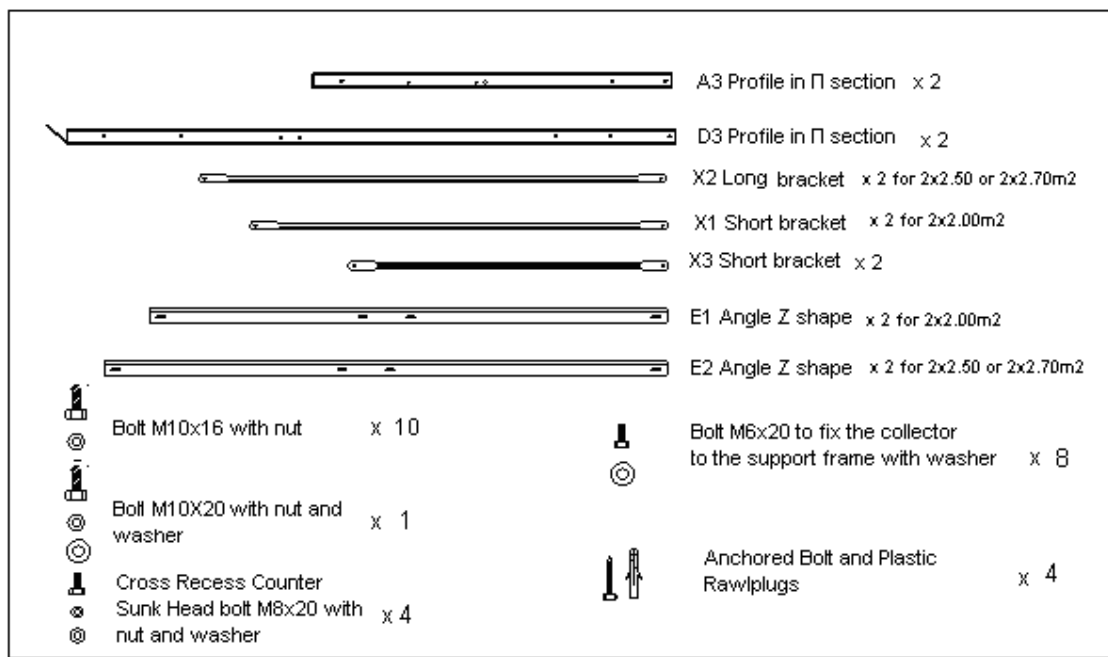

Figure 4. Support frame components EST2 for two solar collectors

The support frames allow the installation of the solar collectors with different inclinations (45, 40, 35 or 30 degrees) using the same profiles and accessories, by choosing properly the fixing holes.

**2.3. Connectors**

The connectors supplied are conical-type compression unions with metal ring and allow the connection of two or more solar collectors in a bank, joining the top and bottom of the collectors.

This way, the collectors are hydraulically connected between them in parallel.

The number of connections provided is determined by the number of collectors in the bank, according to Table 1 above.

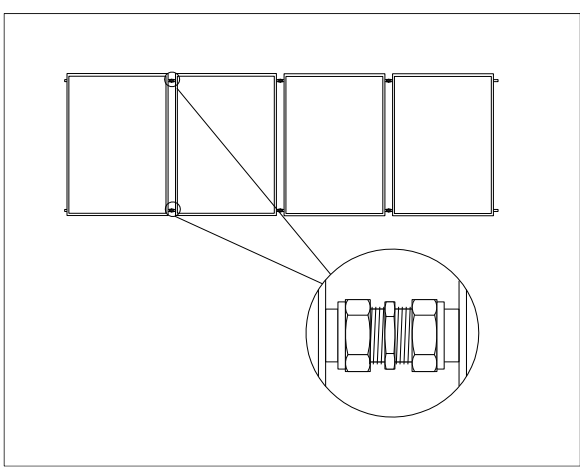

Figure5. Connections

### 3. Placement of the Collectors

The choice of location, inclination and orientation of the solar collectors has to be determined at the design stage of the installation. The installation of the solar collectors in the building should be carried out respecting the instructions of the person in charge of the project, who should have taken into consideration the effect of the orientation, inclination and possible shadows in the calculation of benefits of the solar system.

Particular attention should be paid to the minimum distance maintained between two rows of solar collectors or between an obstacle in front of a group of solar collectors and them. During the calculation of this distance one should take into consideration the latitude of the place, the inclination of the terrain and the period of use of the facility. Failure to have a more detailed specification by the designer of the facility, the distance should not be less than that shown in Figure 6.

At the time of its installation, the solar collectors should be stored in a compound covered and kept in their original packaging. During the assembly phase, avoid keeping the solar collectors outdoors with the cover glass facing down on wet surfaces, in order to prevent entry of humidity or water in the rear of the collector.

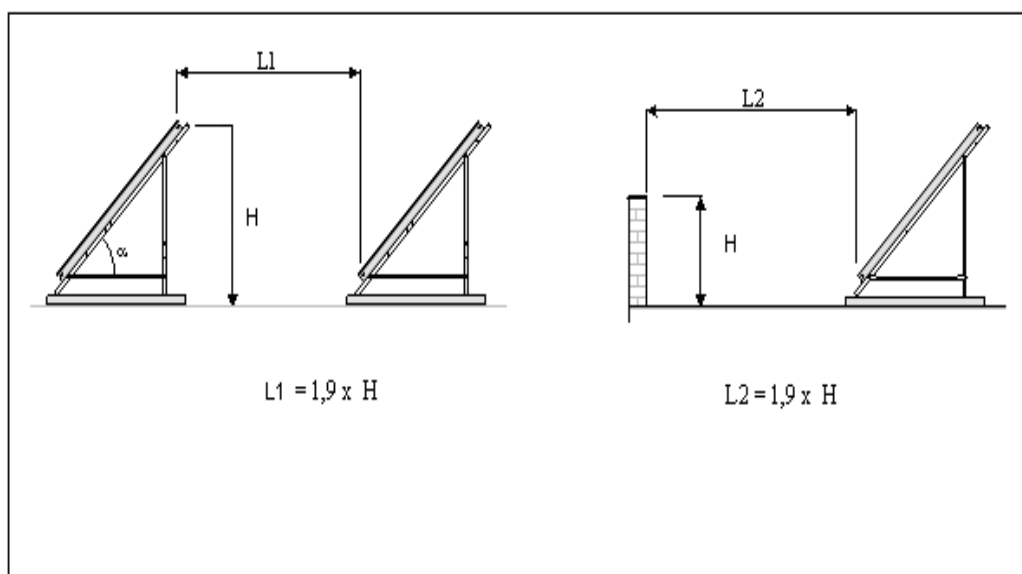

Figure 6. Distance needed in order to avoid shadows on collectors.

Once at work, in the event that the installer observes the existence of elements that can cause shadows on the solar collectors and have not been taken into account in the design of the system, as protection walls in terraces, fireplaces, outdoor air conditioning units or other elements, should inform the designer of the project or the owner of the property in order to revise or amend the calculations made for the location of the collectors, if necessary.

The system of fixing the support frame of the solar collectors to the building also must be determined in the design phase of the installation, for example by conducting benches built on a flat roof. In this case, the thickness and size of the bench should be sufficient to ensure stability of the whole in case of strong gusts of wind. In any case, the solution adopted should ensure the solidity and stability of the setting without compromising the watertight integrity of the deck. To facilitate the design of the fixing system, figures 7 to 13 show the distances between the support frames of the solar collectors.

#### 4. Banks of Collectors

The solar collectors can be connected with each other to form banks of up to 6 units in parallel, connecting the top and bottom of the collectors through the fittings included in the set.

The dimensions of pipe connections for collector arrays up to 20m<sup>2</sup> is 22mm. It is recommended that the connections between the different banks of collectors are also conducted in parallel. However, the connection of up to two banks of solar collectors in series is allowed.

In the following figures from 6 to 13 shows the dimensions of the solar collectors from 1 to 6 units and for different angles of inclination. Additionally, there should be sufficient space around the banks of collectors to perform with comfort the hydraulic connections.

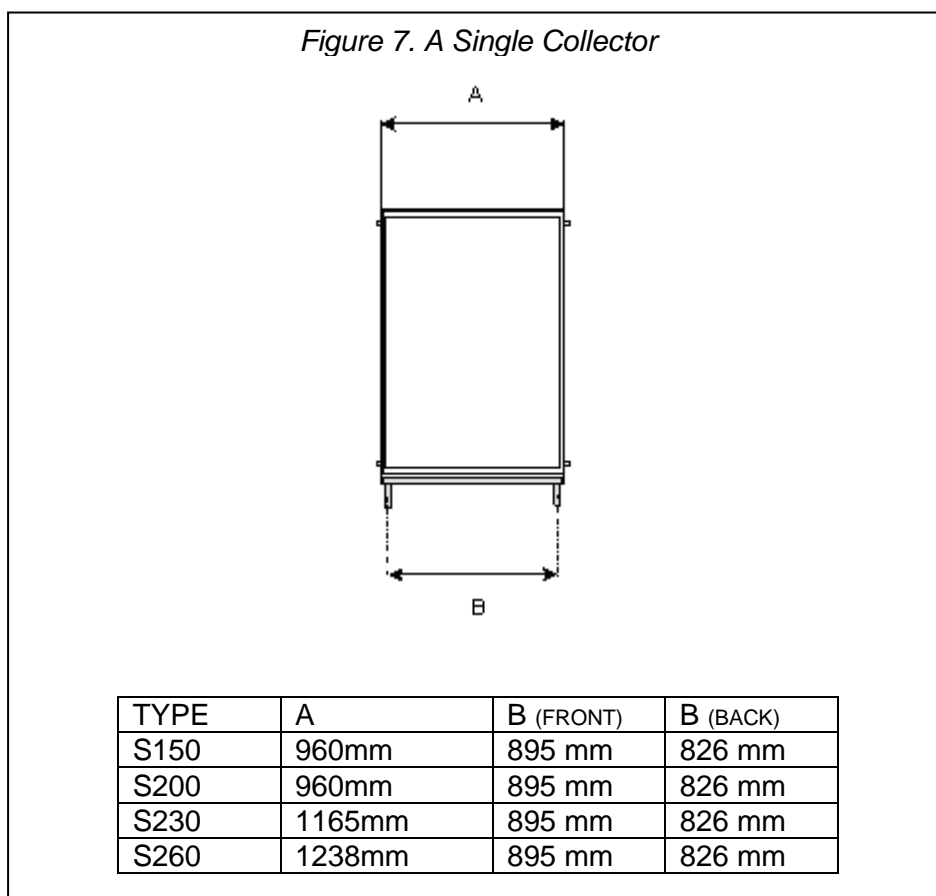
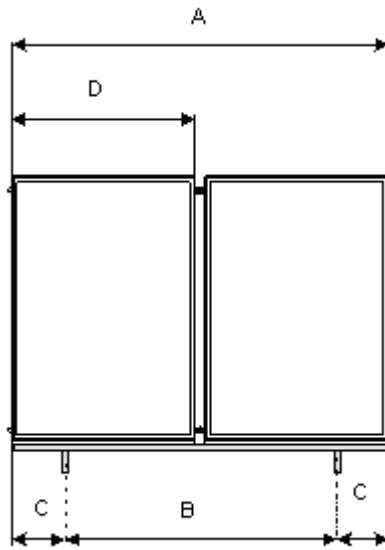
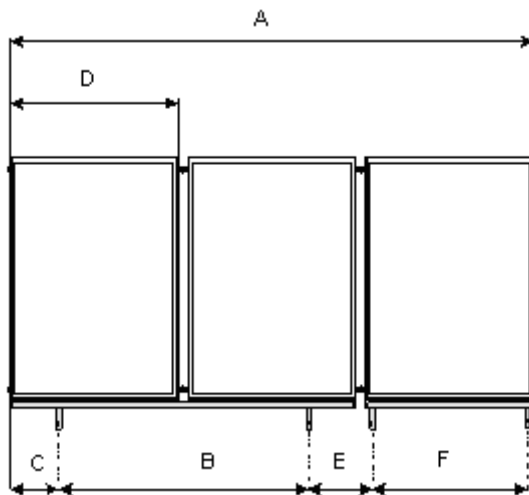

Figure 8. Bank of Two Solar Collectors



| TYPE | A      | B (FRONT) | B (BACK) | C       | D      |
|------|--------|-----------|----------|---------|--------|
| S150 | 1980mm | 895 mm    | 826 mm   | 542,5mm | 960mm  |
| S200 | 1980mm | 895 mm    | 826 mm   | 542,5mm | 960mm  |
| S230 | 2390mm | 1440 mm   | 1370 mm  | 475,0mm | 1165mm |
| S260 | 2536mm | 1440 mm   | 1370 mm  | 548,0mm | 1238mm |

Figure 9. Bank of Three Solar Collectors



| TYPE | A      | B (FRONT) | B (BACK) | C       | D      | E       | F(FRONT) | F(BACK) |
|------|--------|-----------|----------|---------|--------|---------|----------|---------|
| S150 | 3000mm | 895 mm    | 826 mm   | 542,5mm | 960mm  | 667,5mm | 895 mm   | 826 mm  |
| S200 | 3000mm | 895 mm    | 826 mm   | 542,5mm | 960mm  | 667,5mm | 895 mm   | 826 mm  |
| S230 | 3615mm | 1440 mm   | 1370 mm  | 475,0mm | 1165mm | 805,0mm | 895 mm   | 826 mm  |
| S260 | 3834mm | 1440 mm   | 1370 mm  | 548,0mm | 1238mm | 951,0mm | 895 mm   | 826 mm  |

Figure 10. Bank of Four Solar Collectors

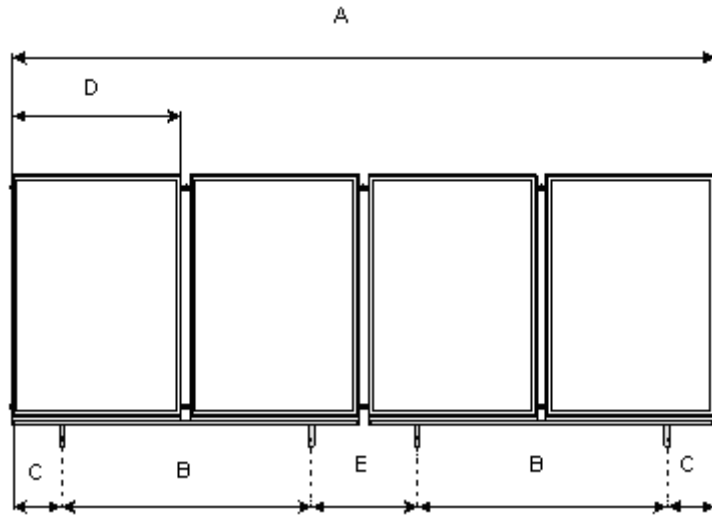

| TYPE | A      | B (FRONT) | B (BACK) | C       | D      | E      |
|------|--------|-----------|----------|---------|--------|--------|
| S150 | 4020mm | 895 mm    | 826 mm   | 542,5mm | 960mm  | 1145mm |
| S200 | 4020mm | 895 mm    | 826 mm   | 542,5mm | 960mm  | 1145mm |
| S230 | 4840mm | 1440 mm   | 1370 mm  | 475,0mm | 1165mm | 1010mm |
| S260 | 5132mm | 1440 mm   | 1370 mm  | 548,0mm | 1238mm | 1156mm |

Figure 11. Bank of Five Solar Collectors

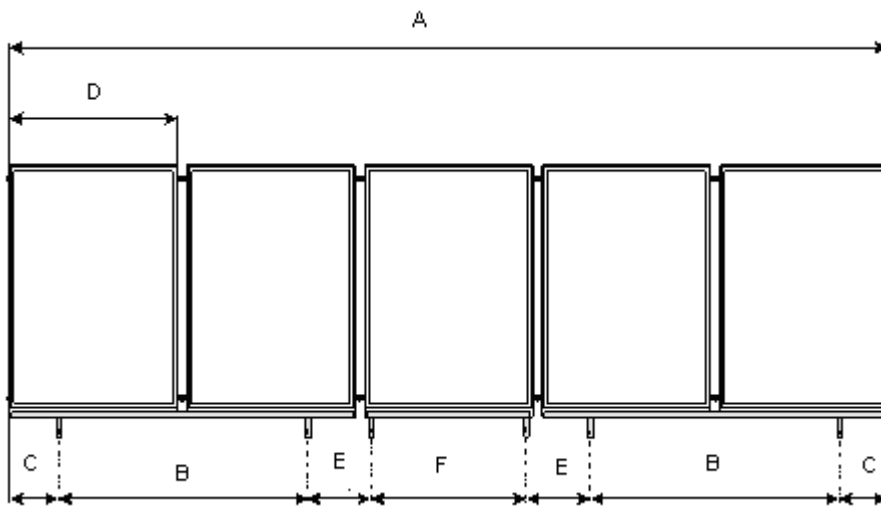

| TYPE | A      | B (FRONT) | B (BACK) | C       | D     | E     | F(FRONT) | F(BACK) |
|------|--------|-----------|----------|---------|-------|-------|----------|---------|
| S150 | 5040mm | 895 mm    | 826 mm   | 542,5mm | 960mm | 635mm | 895 mm   | 826 mm  |
| S200 | 5040mm | 895 mm    | 826 mm   | 542,5mm | 960mm | 635mm | 895 mm   | 826 mm  |

Figure 12. Bank of Six Solar Collectors

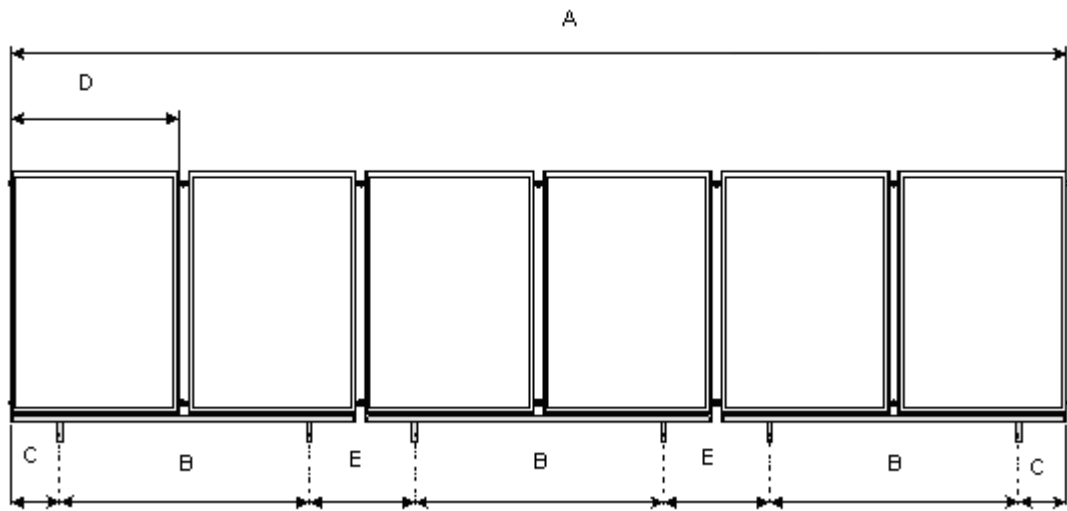

| TYPE | A      | B (FRONT) | B (BACK) | C        | D     | E      |
|------|--------|-----------|----------|----------|-------|--------|
| S150 | 6060mm | 895 mm    | 826 mm   | 542,5 mm | 960mm | 1145mm |
| S200 | 6060mm | 895 mm    | 826 mm   | 542,5 mm | 960mm | 1145mm |

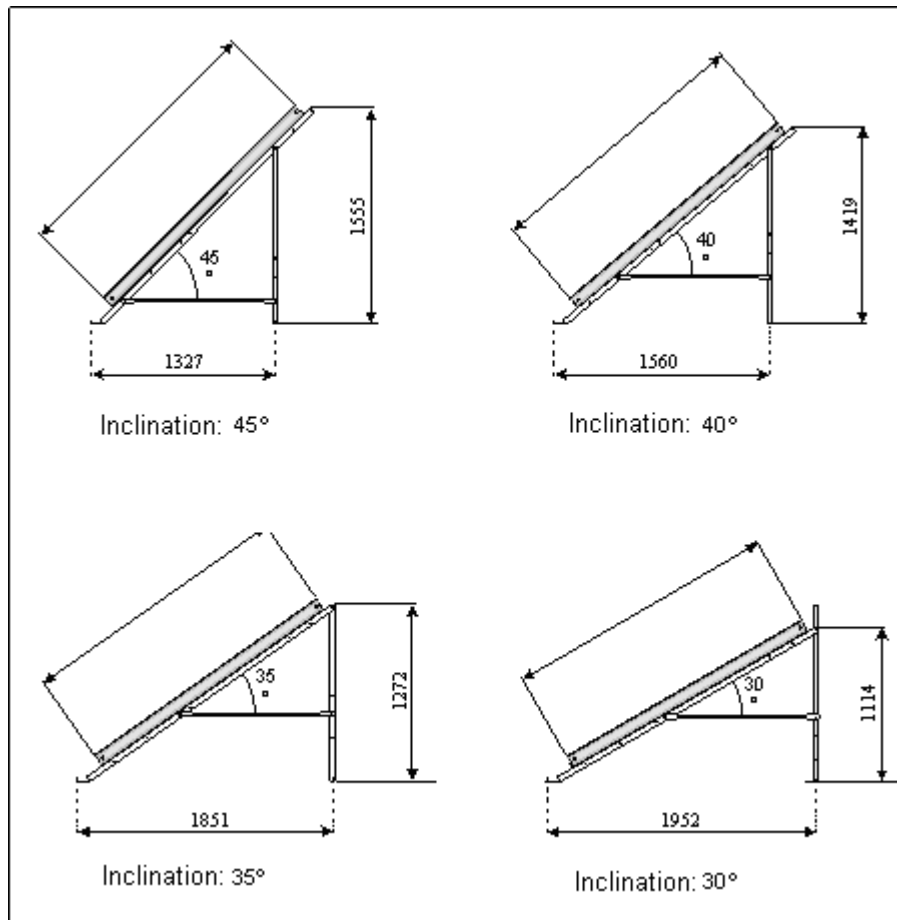

Figure 13. Dimensions of the banks of collectors depending on the inclination. (The above dimensions apply to all sizes of collectors)

## 5. Flat Roof Installation

Next it will be described the procedure for installing a bank of two solar collectors on a flat roof. The formation of more banks of collectors is done simply by adding the support frames EST1 or EST2 when necessary.

### 5.1. Installation of the longitudinal profiles D3 and the Z angles E1/E2

Place the two longitudinal profiles D3 on the floor, at the indicated distance, so that both profiles U remain outward-oriented. Place the two Z angles E1 or E2 over, in the correct position (Figure 14a, 14b & 14c) .

Screw the lower Z angle E1 or E2 to the two longitudinal profiles D3 with two sunk head bolts M8x20 with their nuts and washers and tighten.

Screw the higher Z angle E1 or E2 to the two longitudinal profiles D3 with two sunk head bolts M8x20 with their nuts and washers, without tighten it yet in order to facilitate the subsequent placement of the collectors.

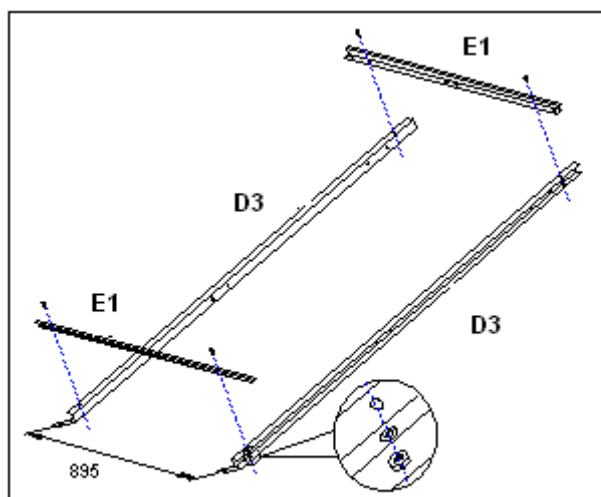

Figure 14 a (for 2x2,00m<sup>2</sup>)

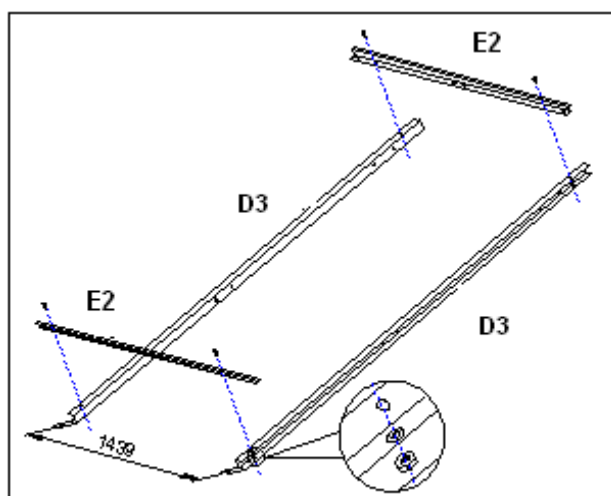

Figure 14 b (for 2x2,50m<sup>2</sup>)

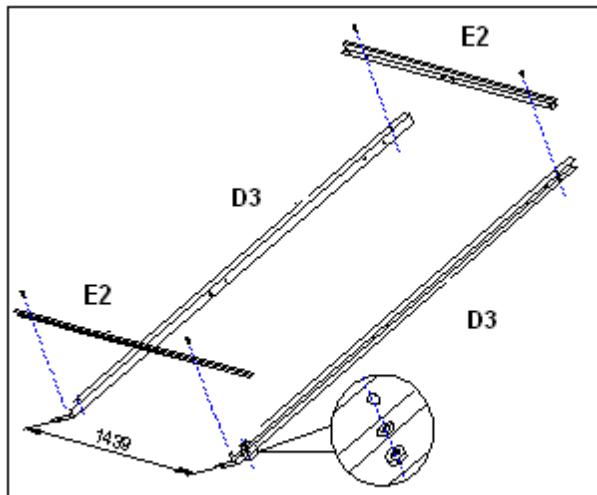

Figure 14 c (for 2x2,70 m<sup>2</sup>)

## 5.2. Installation of the vertical legs A3 and the Long cross pieces X1/X2

Place the two long crosspieces X1 or X2 forming an X, with the convex part of the profiles and link them into contact with each other through a bolt M10x20 with nut and washer, without tighten it yet.

Place the two vertical legs A3 parallel on the floor, so that both U profiles are oriented towards the interior. Screw the long crosspieces X1 or X2 as the cross-legged to the vertical legs A3 using four bolts M10x16 with its nuts. Tighten the four bolts at the ends and the bolt of the central X (Figure 15a and 15b).

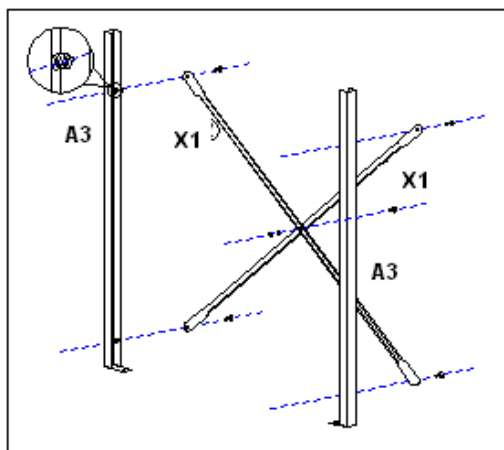

Figure 15a (for 2x2.00m<sup>2</sup>)

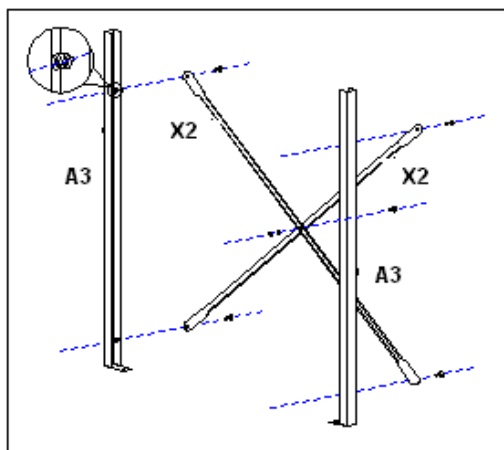

Figure 15b (for 2x2.50m<sup>2</sup> or 2x2.70m<sup>2</sup>)

### 5.3. Installation of the vertical legs A3 and the longitudinal profiles D3

Lift the legs A3 coupled with the X formed with the long crosspieces X1 or X2 until you place them vertically.

Lift the rear part of the longitudinal profiles D3 coupled with the cross profiles E1 or E2 and join to the vertical legs A3, using two holes depending on the inclination that should be given to the collectors (Fig. 16b). Tighten with two bolts M10X16 with its nuts.

Join the short crosspieces X3 to the longitudinal profiles D3 (at its inner surface) and to the rear legs A3 (at its outer face), use the holes depending on the inclination that wants to be given to the collectors (Fig. 16b). Both profiles should be horizontal. Screw with the two bolts M10x16 in each profile, with its respective nuts.

Join the structure to the bench, using the raw plugs and anchored bolts supplied or with the fixing parts suitable to the characteristics of the support frame. In any case, the choice of the solution adopted should avoid compromising the watertight integrity of the roof. (Fig. 16a).

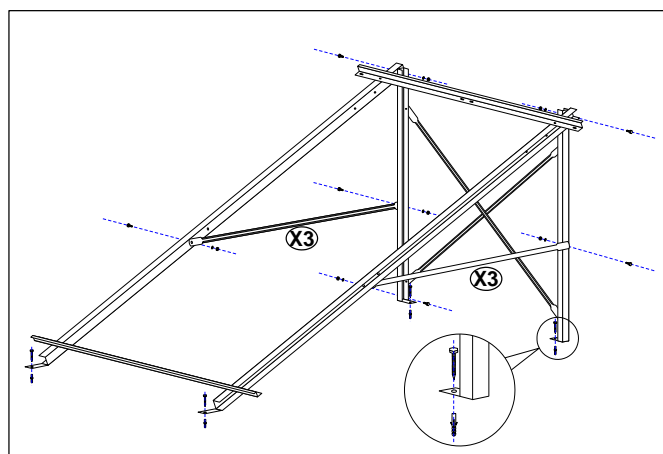

Figure 16a

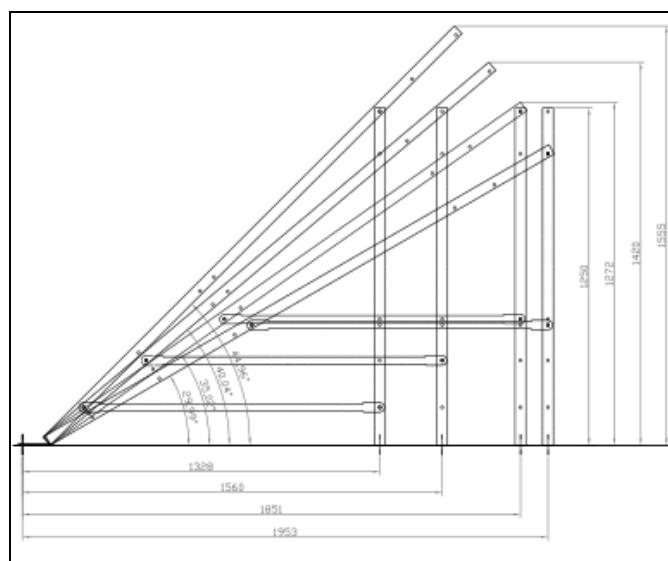

Figure 16b

## 5.4. Placement of Solar Collectors

Place one of the solar collectors in the support frame, place it first on the lower profile cross- E1 or E2 and then on the higher profile cross- E1 or E2. Adjust the position of the solar collector in the structure, so that matches the holes in the structure of the holes in the rear part of the collector (Figure 17).

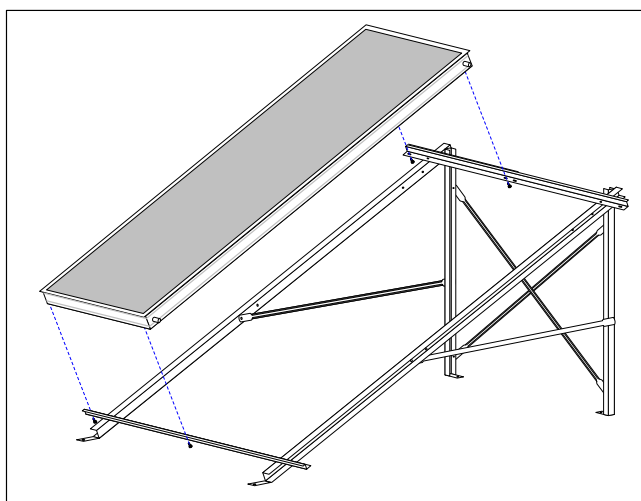

Figure 17.

Remove the protection caps of the collector lateral' connections and introduce the two compression union connectors (see fig. 5).

Remove the protection caps of the connections of the lateral of the second collector and place it on the structure, on the cross profiles E1 or E2 lower and upper.

Slide the second collector so that the end is introduced into the connector. Verify that the connection has been done correctly and that the holes in the structure match those holes back of the collectors. Adjust the position of the collectors if necessary. Adjust the higher cross- E1 or E2 profile to the collectors and tighten the bolts that bind to the longitudinal profiles D3.

Screw the solar collectors to the structure, with the bolts M6x20 (four per collector) with their washers.

Make sure all bolts and the different elements of the structure are properly tightened and check the solidity of the whole and its correct fixing to the bench. The collectors and the support system can withstand wind velocity up to 120km/h and weight of snow up to 80cmheight at 45 degrees.

The bank of two solar collectors is ready to start the hydraulic connections.

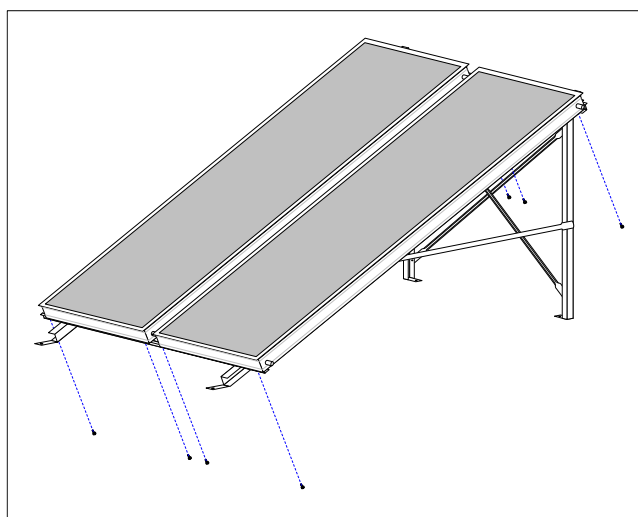

Figure 18.

## 6. Tile roof installation

The assembly of solar collectors on a tile roof is done in a manner similar to that described above, with a different position of the vertical legs A3 that have to be placed horizontally underneath the E1/E2 in a parallel manner. The crosspieces X1 or X2 and X3 shorts are not needed for tile roof installation.

The profiles D3 longitudinal and transverse E1 or E2 have to be fixed to the roof with strength and without compromising its tightness. The fixing procedure will depend on the characteristics of the roof. With the installation fittings are supplied some perforated flexible metal strips to facilitate this fixation on certain roof configurations. (See fig. 19) The collectors and the support system can withstand wind velocity up to 120km/h and weight of snow up to 80cm height at 45 degrees.

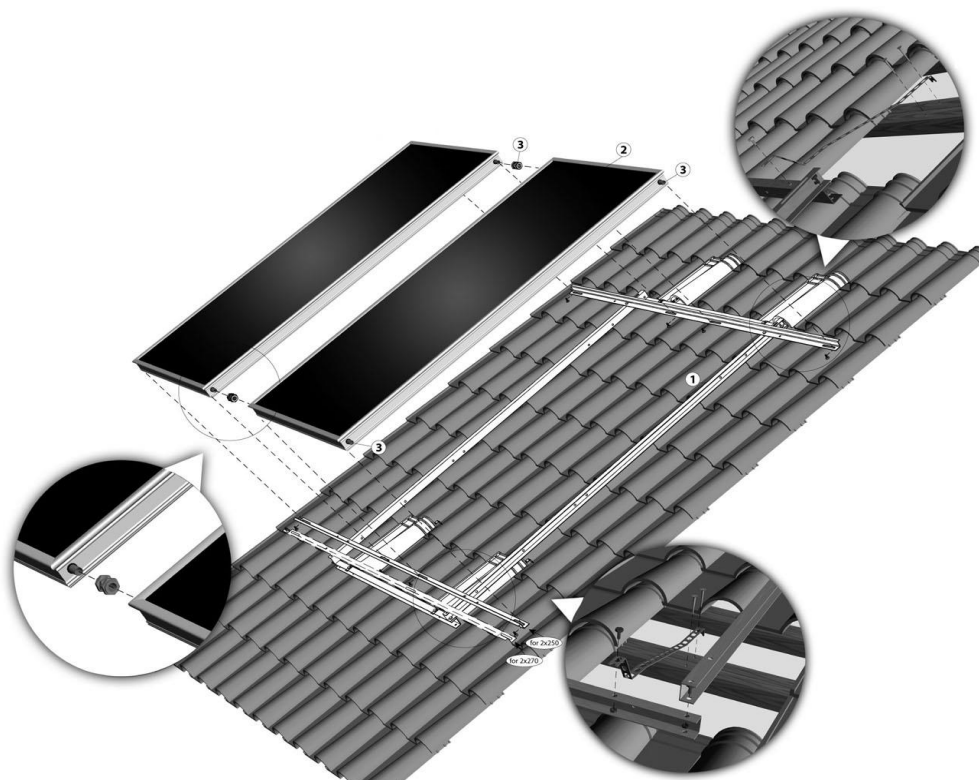

Figure 19.

## 7. Connections and Hydraulic Circuit

The collectors or different groups of solar collectors must be connected hydraulically to form a closed primary solar collection circuit. The use of copper pipes is recommended, with a wall minimum thickness of 1 mm and an adequate diameter for the circulation flow of each part.

The entry of liquid to the group of solar collectors will be from the end at the bottom of the collector. On the top end connection a plug must be installed. The output of liquid will be done by the top of collector's opposite end of each bank. On the top connection an end cap must be installed.

The route of the pipeline will be conducted so as to minimize the parts where the flow of the hot fluid runs (of the collectors towards the tank or to the interchange at the plant room).

In each group of solar collectors two stop valves should be installed at the entrance and exit to allow the hydraulic isolation of the rest of the circuit and a safety valve (figure 20).

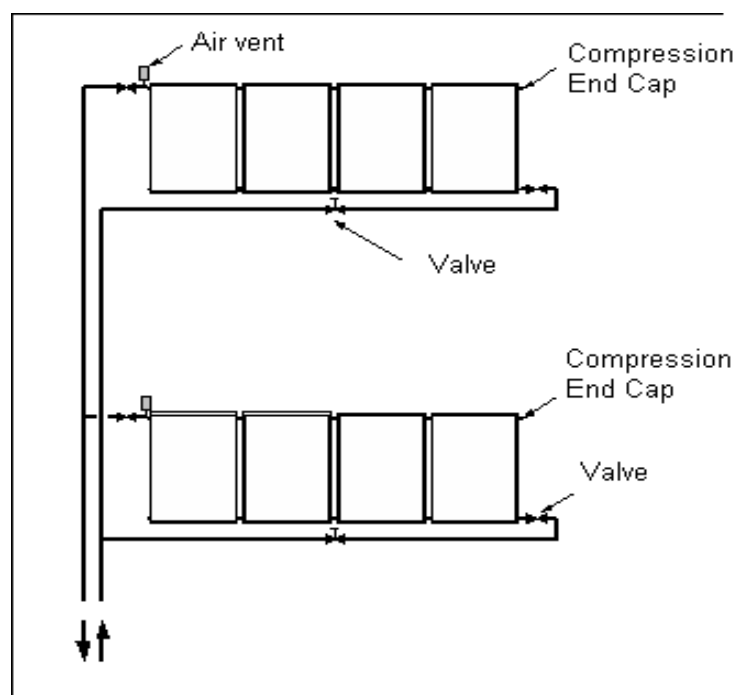

Figure 20. Group of collectors connection.

The solar collectors reach high temperatures, especially in periods of great sunshine and low energy consumption, which can cause significant expansion of the materials. The connection of various groups of solar collectors with each other and / or pipes of hydraulic circuit must be made so as to ensure that expansion does not cause excessive pressure (tensions) on the connections or on the collectors, for example by the use of flexible unions.

In all the high points of the primary circuit of the solar collectors, and particularly the output of each group of collectors, an air vent must be installed, automatic or manual. In any case, the air vent must be capable of withstanding temperatures of up to 150 ° C without deterioration. Once the air is drawn out from the circuit, the vents will remain closed.

A smooth distribution of flow between different groups of solar collectors must be ensured so that each group has a flow rate close to 100 litres / h for each collector that is part of this group (i.e. 400 litres / h for every group of 4 solar collectors). This can be achieved with appropriate design of the route of the pipeline or by installing a balancing valve in each group, properly adjusted. We recommend the second system.

The pressure drop within each collector should be taken into account when selecting the appropriate pump. (figure 21 indicates the pressure drop)

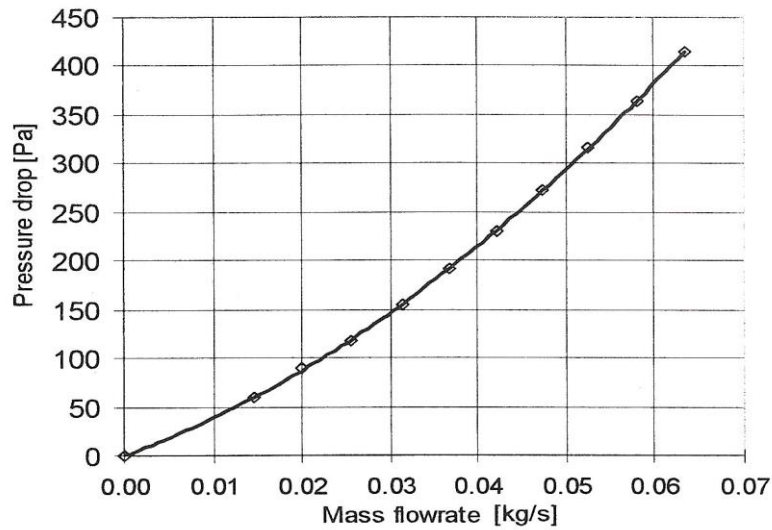

Conditions: Fluid is water at 20 C

Figure 21.

The pipes must be insulated according to existing regulations. The thickness of the insulation material must be at least 30 mm for a material with conductivity equal to 0.040 W/m<sup>2</sup>K. The insulation material must be capable of withstanding pipe surface temperatures higher than 120 ° C without deterioration.

The circulating fluid must contain a sufficient amount of antifreeze liquid to avoid any risk of freezing. The freezing temperature of the fluid circuit of the solar collector should be less than the minimum temperature recorded at the site of the facility. Propylene glycol makes an excellent choice for use as a heat transfer fluid in applications where contact with potable water, food or beverages might occur. Its low toxicity, low freezing point, corrosion-inhibiting composition and high boiling point make it uniquely applicable for use in such applications.

Below is a table showing the freezing temp. of propylene glycol – water fluid with respect to the ratio of pure glycol to the water.

|  |      | Freezing Point |    |    |     |     |     |     |
|--|------|----------------|----|----|-----|-----|-----|-----|
| Propylene Glycol Solution<br>(% by <u>mass</u> ) |      | 0              | 10 | 20 | 30  | 40  | 50  | 60  |
| Temperature                                      | (°C) | 0              | -3 | -8 | -15 | -24 | -36 | -48 |

The primary circuit of the solar collectors must be in accordance with all the necessary security measures, particularly a safety valve correctly set, an expansion tank designed to even take into account the evaporation of liquid contained in the collectors and a system of protection against overheating (heat sink or similar), if necessary.

The primary circuit of the solar collectors must have at least a thermometer and a manometer to permit recording of the temperature and the pressure of the circuit.

Before the final filling of the primary circuit, internal washing with domestic water should be carried out to remove any dirt or rests and pressure test should be carried out to verify the sealing of all, without exceeding the maximum pressure allowed by solar collectors. This is to verify that the connections between solar collectors have no leaks. If that is so, the fittings should be tightened, using two keys, so as to avoid transmitting force (torsion) to the pipes of the absorbers of the solar collectors. (Figure 22)

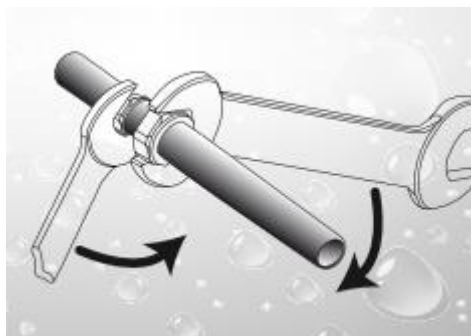

Figure 22

During the final filling of the solar system with antifreeze fluid it must be verified that the circuit is perfectly purged and pressurized. Once this operation is finalized, the air vents should be closed.

It should be avoided to carrying out operations such as washing and filling the primary circuit while or after the solar collectors are exposed to intense sun.

## 8. Lightning Protection

National norms and regulations over lightning protection should be closely followed. In any case the support(s) of the collectors must be “earthed” with copper wire of 16mm<sup>2</sup> to the ground grid of the building. This will serve as lightning protection.

This guideline does not release in any way the installer from his responsibility against lightning protection requirements.

## 9. Permissible wind and snow load

Permissible negative pressure for wind load is 1500 Pa

Permissible positive pressure for snow load is 2000 Pa

## 10. Care and Maintenance Program

- The collectors should be subject to periodic visual inspections. If it appears that excessive dirt has been accumulated on the glass of the collectors, then it must be cleaned. This operation should take place during the morning, before 10:00 am or in the afternoon after the 18:00 pm, checking before that the collectors are not too hot. Otherwise, there might be a risk of damaging the collector, (especially when using a hose), or burning if manual cleaning is performed.
- If for some reason the collector's glass breaks, it should be replaced immediately. Otherwise, the interior of the collector may deteriorate due to rain, humidity or dirt.
- During each inspection, visually check the possible loss of tightness in the closed-circuit connections and the entry and exit of each collector and the connections between them. Fix if necessary or replace items (parts) in poor condition.
- The support of solar collector is made of highly resistant galvanized steel. As a precaution, check regularly their condition and repair if necessary. Verify also fixations to the tile or flat roof.
- In the event that an extended period without hot water consumption is foreseen (for example during holidays) it is recommended to cover the collectors with a blanket or a similar opaque material or empty the collectors circuit, so as to avoid unnecessary overheating. The cover of the collectors must be well fixed to avoid being gone by the wind.
- The closed circuit of the collectors should be suitably protected against frost with antifreeze liquid of the right characteristics. Particular attention should be given not to reduce the concentration of antifreeze mixture, for example by filling with water.





**Published: July 2017**  
**Version 3**

**SOLE S.A.**  
**SOLAR DOMESTIC APPLIANCES MANUFACTURER**  
**Lefktron & Laikon Agonon, 136 71 Acharnai – Athens – Greece**  
**Tel.: (+30210) 2389500 • Fax: (30210) 2389502**  
**Email: [export@sole.gr](mailto:export@sole.gr) • [www.eurostar-solar.com](http://www.eurostar-solar.com)**