

**INSTALLATION
&
USERS MANUAL**



DOMESTIC SOLAR WATER HEATER

S O L E
EUROSTAR

THERMOSIPHON SYSTEM

CLOSED CIRCUIT

MODELS EUROSTAR ECO :

125-1-S150, 125-1-S200, 150-1-S200, 150-1-S230, 150-2-S150, 200-1-S200, 200-1-S230, 200-1-S260, 200-2-S200, 300-2-S200, 300-2-S230

INDEX

INDEX.....	2
1. Observance of the instructions and standards.....	3
2. Description of solar system and components	3
2.1 General Description.....	3
2.2. Collector.....	4
2.3. Accumulation tank (cylinder).....	4
2.4 Support system.....	5
2.5. Thermo convention liquid	7
2.6. Packaging, Transport and Storage	7
3. Warnings.....	8
4. Recommendations.....	6
5. Flat Roof.....	15
Assembly instructions for systems with 1 collector:	15
Models: 125-1-S150, 125-1-S200, 150-1-S200, 150-1-S230, 200-1-S200, 200-1-S230, 200-1-S260.....	15
Assembly instructions for systems with 2 collectors:.....	17
Models: 150-2-S150, 200-2-S200, 300-2-S200, 300-2-S230.....	17
7. Inclined roof - Tiles	19
Assembly instructions for systems with 1 collector :	19
Models: 125-1-S150, 125-1-S200, 150-1-S200, 150-1-S230, 200-1-S200, 200-1-S230, 200-1-S260.....	19
Assembly instructions for systems with 2 collectors:.....	21
Models: 150-2-S150, 200-2-S200, 300-2-S200, 300-2-S230.....	21
9. Check list for installer	23
10. Operation instructions.....	24
11. Maintenance instructions.....	24
12. Decommissioning of the system.....	24

1. Observance of the instructions and standards.

1.1. It is very important to follow these installation, operating and maintenance instructions, in order to avoid danger of death, injury, property damages, and to have your device functioning properly in the long run. The company that manufactured and/or supplied this solar system has no liability for the installer and/or the user in case these instructions have not been followed carefully.

1.2. Whether further information or clarifications are needed, please contact the supplier of the product.

1.3. These solar systems have been manufactured and tested under the European standards:

- ISO 9806:2013: Energy – Solar Thermal Collectors – Test methods
- EN 12975-1: Thermal solar systems and components – Solar collectors -part 1: General requirements.
- EN 12975-2: Thermal solar systems and components – Solar collectors – part 2 : Test methods.
- EN 12976-1: Thermal solar systems and components – Factory made systems - part 1: General requirements.
- EN 12976-2: Thermal solar systems and components – Factory made systems – part 2: Test methods.

1.4. These systems are in conformity with the applicable requirements of the following documents:

<i>Ref. No.</i>	<i>Title</i>
EN 60335-1:2012 +A11:2014 (IEC 60335-1:2010)	Household and similar electrical appliances — Safety — Part 1: General requirement
EN 60335-2-21:2003 +A2:2008 (IEC 60335-2-21:2002 +A2:2008)	Household and similar electrical appliances — Safety — Part 2-21: Particular requirements for storage water heaters
EN 60529:1991 +A1:2000 +A2:2013 (IEC 60529:1989 +A1:1999 +A2:2013)	Degrees of protection provided by enclosures (IP code)
ENV 61024-1:1995 (IEC 61024-1:1990)	Protection of structures against lightning Part 1: General principles

The manufacturer declares that the equipment named in this document have been designed to comply with the relevant sections of the above referenced specifications.

2. Description of solar system and components

2.1 General Description

This solar system is a closed loop thermosiphon unit which delivers hot water for domestic use. It consists from the collector, the accumulation tank, the support system, the hydraulic accessories and the thermo-convention liquid.

Four nominal sizes of accumulation tanks are combined with four different sizes of collectors as the table below:

MODEL	TANK NOMINAL SIZES				COLLECTOR NOMINAL SIZES			
	125 ltrs	150 ltrs	200 ltrs	300 ltrs	1,50m ²	2,00m ²	2,30m ²	2,60m ²
125-1-150	1				1			
125-1-200	1					1		
150-1-200		1				1		
150-1-230		1					1	
150-2-150		1			2			
200-1-200			1			1		
200-1-230			1				1	
200-1-260			1					1
200-2-200			1			2		
300-2-200				1		2		
300-2-230				1			2	
Other combinations are available upon request								

2.2. Collector

The collectors are manufactured in 4 sizes with nominal area of 1,50m² -2, 00m²-2.30m² -2,60m². The absorbers of the collectors are made by copper tubes and the fins area by selective aluminum fins. The fins are welded to the tubes by laser welding. The frame of the collector is made by extruded aluminum epoxy oven painted to resist ambient conditions.

The glass cover is a “prismatic securit” glass of 3.2mm thickness for maximum penetration of solar irradiation. At the back and sides of the absorber there is sufficient insulation of rock wool and glass wool to minimize heat loses and to resist stagnation temperatures.

Technical data of collector as the table below:

	Nominal size (m ²)			
	1,50	2,00	2,30	2,60
Length (mm)	1540	1960	1960	2135
Width (mm)	960	960	1165	1238
Depth (mm)	81	81	81	81
Weight (kg)	27,3	32,0	38,8	44

Stagnation temperature: 164°C

Test pressure: 22.5 bar

Operating pressure: 15bar

2.3. Accumulation tank (cylinder)

The solar accumulation tank is an indirect (double circuit) hot water horizontal cylinder. The inner surface is enameled at 850°C to guarantee potable sanitary water for long life. Additionally it is protected against rusting with a large magnesium anode.

The ecologic polyurethane foam insulation guaranties minimum thermal loses even at very low ambient temperatures. The external cover of the tank can resist any extreme weather conditions for life. The internal heat exchanger with large surface guaranties the energy transfer to the domestic hot water.

The hot water exits from the hottest zone (level) of the tank. At the same time equal quantity of cold water enters the tank at the coldest zone (level). The solar tank can be optionally (accessory) equipped with immersion electric heater (electric element) for use only for emergency situations. The immersion electric heater is available in 2 kW or 3kW or 4 kW at 230 Volt. It is equipped with control thermostat set at 60° C and safety thermostat (thermal cut out) manually reset.

The safety valve only opens to discharge when the system pressure exceeds 10bar in the form of water.

Technical Data of tanks as table below:

	Nominal size			
	125	150	200	300
Length (mm)	1130	1185	1215	1915
Diameter (mm)	440	500	530	530
Weight (kg)	35	46,7	50,8	83
Capacity (ltr) (Incl. h.exchanger)	115	142	170	276
Test pressure (kPa)	1500	1500	1500	1500
Operating pressure (kPa)	1000	1000	1000	1000
Max temperature (°C)	90 °C	90 °C	90 °C	90 °C
Cold & hot water connectors (male)	½"	½"	½"	½"

2.4 Support system

The support system is made from galvanized pressed steel. It is designed for flat roof installation as well as for inclined tiled roof. It can be installed at 3 different inclinations. 20°-30°-40°, so it can meet any roof slope. The support system can withstand wind velocity up to 97,2 km/hr. and weight of snow up to 64cm height.

In order to assembly the support system the following tools are needed.

- Spanner 10mm 1 X 
- Spanner 13mm 1 X 
- 2 Spanners 17mm 2 X 
- Screwdriver 1 X 
- Drill Ø10 (for fastening the system on the roof) 

2.5. Thermo convention liquid

The thermal energy collected from the solar irradiation by the collector is transferred to the heat – exchanger of the tank by the thermo convention liquid, which is naturally re circulated by the thermosiphonic principle in the closed loop system. The heat exchanger is heating the domestic consumption water. The solution contains inhibitors for antirust protection and propylenoglycol for antifreeze protection up to -15°C. If lower temperature protection is needed please consult your supplier.

The solution is a non toxic, non-flammable chemical liquid; however normal protection measures should be taken during handling. Keep it away from children.

Eyes protection: Protective glasses must be used.

Skin protection: PVC or rubber gloves must be used.

- In case of contact with eyes, wash eyes with plenty of water for 15 minutes (with open eyelids)
- In case of contact with skin simply wash with water and soap.

Physical Properties:

Phase: liquid

Color: Light red

Odor: nearly odorless

Specific gravity at 20°C : 1,03g/cm³

Freezing point: -15°C

Boiling point: 106°C

Packing: Containers of 2ltr. & 4ltr. ready for usage.

2.6. Packaging, Transport and Storage

The solar collectors and the solar tanks are supplied individually packaged, the collectors in carton boxes and the tanks with stretch film and expanding polystyrene. The collector model is indicated on the outside of each box and the tank model is indicated outside of each package. Depending on the number of units ordered, collectors can be supplied palletised in groups of up to 12 units. Collectors should always be during transport and storage placed in horizontal position with the glass facing on top, otherwise there is danger of water entering in the collectors from the ventilation holes at the back of the collector. They should not be stored or transported in piles of more than 12 units. The tanks can be supplied palletised in groups of up to 10 units. Alternatively, under request, the whole system can be palletised in individual pallets. The tanks should be always in vertical position during transportation and should not be stored or transported in piles of more than 2 units. It is recommended to use special safety belts during transportation in order to avoid movements and/or falling. The support system, the hydraulic accessories and the thermo-convention liquid are delivered in one pallet, the exact content and models are indicated on the outside of each pallet.

2.7. Placement of the System

The choice of location, inclination and orientation of the solar system has to be determined at the design stage of the installation. The installation of the solar system in the building should be carried out respecting the instructions of the person in charge of the project, who should have taken into consideration the effect of the orientation, inclination and possible shadows in the calculation of benefits of the solar system.

Particular attention should be paid to the minimum distance maintained between a wall or obstacle in front of a system and it. During the calculation of this distance one should take into consideration the latitude of the place, the inclination of the terrain and the period of use of the facility. Failure to have a more detailed specification by the designer of the facility, the distance should not be less than the indicated below.

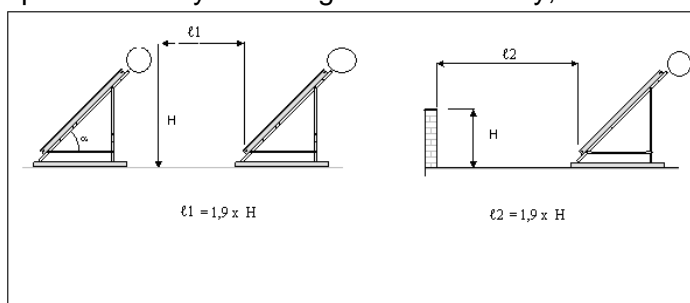

3. Warnings

Before starting installation, the installer should read and observe carefully the following warnings in order to avoid danger of death, injury or property damages.

3.1. You may elevate on roof the parts of the solar system, ONLY when an internal staircase of enough width, exists in the building reaching the roof. Otherwise you must use a proper CRANE to elevate the parts. It is not allowed to stand at the edge of any roof (flat or inclined) and pull by ropes any part. DANGER OF DEATH.

3.2 The collectors have a large surface exposed to wind. NEVER install a system with strong winds. Choose a calm day. DANGER OF DEATH or heavy injury.

3.3. If the installation will be on an inclined roof (tiles), there is danger of slipping. Use always SAFETY BELTS (securely fastened) from a higher position of roof. DANGER OF DEATH.

3.4. After completion of the installation make sure that all bolts and nuts are fastened well and the whole system is securely fastened to the roof. The support system can withstand air velocities up to 97,2 km/hr. Make sure that the fastening on roof can withstand as well at least same air velocity. DANGER OF DEATH.

3.5. Frequently some parts of the support systems have sharp edges. Use always gloves when you are handling the support system, in order to avoid danger of injuring the hands. DANGER OF INJURY.

3.6. The collectors when exposed to solar irradiation during installation get very hot; above 120° C in 2-3 minutes. There is danger of burning the hands when touching the copper piping outlets. You must leave the carton package cover ON the glass until completion of the installation, or you must use thermo resistance gloves. DANGER OF INJURY.

3.7. If you are using hands to position the tank on the support system at least 2 people are needed for systems 120-150.

It is preferred to use a crane. In this case make sure that the pulling belts are on each side between the piping outlets of the boiler so that it cannot slip.

3.8. In cases where the solar system is large and the hot water consumption is low, the hot water in the solar tank may reach temperatures up to 90°C. In this case there is danger of burns for the user, especially for children.

It is strongly recommended to install a thermostatic mixing valve set at 55°C anywhere at the hot supply piping and before the hot outlets of the building (before taps, showers, e.t.c.)

3.9. If the solar system is equipped with the (optional) electric immersion heater, the electrical connection should be done by a fully licensed electrician following the national rules for electric installation.

The immersion heater is single phase 230 Volt of 2kW or 3 kW or 4 kW power.

There is an "earth point" on the flange of the heater which must be connected to the central "earth" of the building. In any case the support of the solar system must be "earthed" with copper wire of 16 mm² to the earthing grid of the building. This will also serve as lightning protection.

3.10 In a solar system equipped with the optional electric heater, after completion of electrical and plumbing installation test the operation of the electric heater and thermostat, ONLY AFTER FILLING the tank with city water. Otherwise the electric heater will be fused out. (destroyed)

3.11 Make sure that before filling the tank with city water the pressure safety non-return valve has been installed on the cold water inlet with the arrow pointing to the tank. This valve will open and release the pressure when by overheating or other reason it has exceeded 10 bar.

3.12. When handling the thermo-convention liquid make sure that you wear protective glasses for the eyes and gloves for the skin.

3.13. When temporarily leave the collectors on the roof during installation ALWAYS position them with glass facing the sky. Otherwise there is danger that water from rain may enter the collector from the back side through the ventilation holes. If this happens the insulation will be wet and the glass will have humidity on inside surface. Drying will take a very long time.

4. Recommendations

4.1 The cold water piping should withstand pressure of 1000 kPa. The hot water piping should withstand temperature of 95° C at pressure 1000 kPa.

4.2. The cold and hot water piping should be well insulated to eliminate heat losses and prevent as possible freezing. The insulation material should withstand weather conditions like rains, snow and solar irradiation.

4.3. The system should be protected always with antifreeze liquid as supplied by the company to prevent from frost.

4.4. On the hot water supply piping, install a reliable thermostatic mixing valve set at 55°C to prevent higher temperature hot water to reach the consumption points.

4.5. The system may only be installed in locations with lower values of s_k (snow load) 0.64m and v_m (average wind velocity) 97.2km/h

4.6. The required solar irradiation for which overheating will happen is shown on the table below. The system should not be used in climate zones with higher irradiation values than these.

SWH 200-2-S200	
H (MJm-2)	T_{sn} (°C)
15.20	31.72
25.01	32.13
19.42	28.69
24.16	30.98
26.42	31.48
26.88	31.62
27.42	32.88
27.94	35.07
27.40	33.82
26.59	35.01
27.21	35.75

4.7. Thermal Performance of the System

Model 125-1-S150

<i>Performance indicators for solar-only systems on annual base for a demand value of 50 l d⁻¹</i>			
Περιοχή (Γεωγ. Πλάτος) <i>Location (latitude)</i>	Q _d MJ	Q _L MJ	f _{sol} %
Stockholm (59.2° N)	2791	1514	54.3
Wuerzburg (49.5° N)	2677	1536	57.3
Davos (46.5° N)	3027	2277	75.2
Athens (38.0° N)	2078	1829	88.0

<i>Performance indicators for solar-only systems on annual base for a demand value of 80 l d⁻¹</i>			
Περιοχή (Γεωγ. Πλάτος) <i>Location (latitude)</i>	Q _d MJ	Q _L MJ	f _{sol} %
Stockholm (59.2° N)	4478	1949	43.6
Wuerzburg (49.5° N)	4289	2028	47.3
Davos (46.5° N)	4857	2870	59.2
Athens (38.0° N)	3343	2567	77.2

<i>Performance indicators for solar-only systems on annual base for a demand value of 110 l d⁻¹</i>			
Περιοχή (Γεωγ. Πλάτος) <i>Location (latitude)</i>	Q _d MJ	Q _L MJ	f _{sol} %
Stockholm (59.2° N)	6150	2255	36.7
Wuerzburg (49.5° N)	5897	2372	40.3
Davos (46.5° N)	6654	3280	49.2
Athens (38.0° N)	4573	3147	68.8

<i>Performance indicators for solar-only systems on annual base for a demand value of 140 l d⁻¹</i>			
Περιοχή (Γεωγ. Πλάτος) <i>Location (latitude)</i>	Q _d MJ	Q _L MJ	f _{sol} %
Stockholm (59.2° N)	7821	2416	30.9
Wuerzburg (49.5° N)	7506	2592	34.6
Davos (46.5° N)	8483	3532	41.8
Athens (38.0° N)	5834	3595	61.5

<i>Performance indicators for solar-only systems on annual base for a demand value of 170 l d⁻¹</i>			
Περιοχή (Γεωγ. Πλάτος) <i>Location (latitude)</i>	Q _d MJ	Q _L MJ	f _{sol} %
Stockholm (59.2° N)	9492	2517	26.5
Wuerzburg (49.5° N)	9114	2655	29.2
Davos (46.5° N)	10281	3595	35.0
Athens (38.0° N)	7064	3753	53.2

<i>Performance indicators for solar-only systems on annual base for a demand value of 200 l d⁻¹</i>			
Περιοχή (Γεωγ. Πλάτος) <i>Location (latitude)</i>	Q _d MJ	Q _L MJ	f _{sol} %
Stockholm (59.2° N)	11164	2573	23.0
Wuerzburg (49.5° N)	10691	2756	25.7
Davos (46.5° N)	12110	3721	30.7
Athens (38.0° N)	8326	3910	47.1

<i>Performance indicators for solar-only systems on annual base for a demand value of 250 l d⁻¹</i>			
Περιοχή (Γεωγ. Πλάτος) <i>Location (latitude)</i>	Q _d MJ	Q _L MJ	f _{sol} %
Stockholm (59.2° N)	13939	2662	19.1
Wuerzburg (49.5° N)	13371	2854	21.3
Davos (46.5° N)	15137	3816	25.3
Athens (38.0° N)	10407	4068	39.2

<i>Performance indicators for solar-only systems on annual base for a demand value of 300 l d⁻¹</i>			
Περιοχή (Γεωγ. Πλάτος) <i>Location (latitude)</i>	Q _d MJ	Q _L MJ	f _{sol} %
Stockholm (59.2° N)	16746	2690	16.1
Wuerzburg (49.5° N)	16052	2867	17.9
Davos (46.5° N)	18165	3847	21.1
Athens (38.0° N)	12488	4100	32.9

<i>Performance indicators for solar-only systems on annual base for a demand value of 400 l d⁻¹</i>			
Περιοχή (Γεωγ. Πλάτος) <i>Location (latitude)</i>	Q _d MJ	Q _L MJ	f _{sol} %
Stockholm (59.2° N)	22327	2722	12.2
Wuerzburg (49.5° N)	21413	2892	13.5
Davos (46.5° N)	24220	3879	16.0
Athens (38.0° N)	16651	4131	24.9

Model 125-1-S200

<i>Performance indicators for solar-only systems on annual base for a demand value of 50 l d⁻¹</i>			
Περιοχή (Γεωγ. Πλάτος) <i>Location (latitude)</i>	Q _d MJ	Q _L MJ	f _{sol} %
Stockholm (59.2° N)	2791	1618	58.0
Wuerzburg (49.5° N)	2677	1624	60.7
Davos (46.5° N)	3027	2438	80.5
Athens (38.0° N)	2078	1892	90.9

<i>Performance indicators for solar-only systems on annual base for a demand value of 80 l d⁻¹</i>			
Περιοχή (Γεωγ. Πλάτος) <i>Location (latitude)</i>	Q _d MJ	Q _L MJ	f _{sol} %
Stockholm (59.2° N)	4478	2148	48.1
Wuerzburg (49.5° N)	4289	2208	51.6
Davos (46.5° N)	4857	3217	66.1
Athens (38.0° N)	3343	2718	81.7

<i>Performance indicators for solar-only systems on annual base for a demand value of 110 l d⁻¹</i>			
Περιοχή (Γεωγ. Πλάτος) <i>Location (latitude)</i>	Q _d MJ	Q _L MJ	f _{sol} %
Stockholm (59.2° N)	6150	2532	41.2
Wuerzburg (49.5° N)	5897	2646	45.0
Davos (46.5° N)	6654	3721	55.9
Athens (38.0° N)	4573	3406	74.2

<i>Performance indicators for solar-only systems on annual base for a demand value of 140 l d⁻¹</i>			
Περιοχή (Γεωγ. Πλάτος) <i>Location (latitude)</i>	Q _d MJ	Q _L MJ	f _{sol} %
Stockholm (59.2° N)	7821	2740	35.1
Wuerzburg (49.5° N)	7506	2939	39.2
Davos (46.5° N)	8483	4068	47.9
Athens (38.0° N)	5834	3910	67.3

<i>Performance indicators for solar-only systems on annual base for a demand value of 170 l d⁻¹</i>			
Περιοχή (Γεωγ. Πλάτος) <i>Location (latitude)</i>	Q _d MJ	Q _L MJ	f _{sol} %
Stockholm (59.2° N)	9492	2873	30.3
Wuerzburg (49.5° N)	9114	3027	33.3
Davos (46.5° N)	10281	4163	40.4
Athens (38.0° N)	7064	4194	59.5

<i>Performance indicators for solar-only systems on annual base for a demand value of 200 l d⁻¹</i>			
Περιοχή (Γεωγ. Πλάτος) <i>Location (latitude)</i>	Q _d MJ	Q _L MJ	f _{sol} %
Stockholm (59.2° N)	11164	2942	26.4
Wuerzburg (49.5° N)	10691	3154	29.4
Davos (46.5° N)	12110	4289	35.5
Athens (38.0° N)	8326	4447	53.5

<i>Performance indicators for solar-only systems on annual base for a demand value of 250 l d⁻¹</i>			
Περιοχή (Γεωγ. Πλάτος) <i>Location (latitude)</i>	Q _d MJ	Q _L MJ	f _{sol} %
Stockholm (59.2° N)	13939	3056	21.9
Wuerzburg (49.5° N)	13371	3280	24.5
Davos (46.5° N)	15137	4447	29.3
Athens (38.0° N)	10407	4667	44.9

<i>Performance indicators for solar-only systems on annual base for a demand value of 300 l d⁻¹</i>			
Περιοχή (Γεωγ. Πλάτος) <i>Location (latitude)</i>	Q _d MJ	Q _L MJ	f _{sol} %
Stockholm (59.2° N)	16746	3094	18.5
Wuerzburg (49.5° N)	16052	3311	20.5
Davos (46.5° N)	18165	4447	24.5
Athens (38.0° N)	12488	4699	37.7

<i>Performance indicators for solar-only systems on annual base for a demand value of 400 l d⁻¹</i>			
Περιοχή (Γεωγ. Πλάτος) <i>Location (latitude)</i>	Q _d MJ	Q _L MJ	f _{sol} %
Stockholm (59.2° N)	22327	3138	14.0
Wuerzburg (49.5° N)	21413	3343	15.6
Davos (46.5° N)	24220	4478	18.5
Athens (38.0° N)	16651	4762	28.7

Model 150-1-S200*Performance indicators for solar-only systems on annual base for a demand value of 50 l d⁻¹*

Περιοχή (Γεωγ. Πλάτος) <i>Location (latitude)</i>	Q _d MJ	Q _L MJ	f _{sol} %
Stockholm (59.2° N)	2791	1599	57.3
Wuerzburg (49.5° N)	2677	1615	60.3
Davos (46.5° N)	3027	2409	79.6
Athens (38.0° N)	2078	1889	90.8

Performance indicators for solar-only systems on annual base for a demand value of 80 l d⁻¹

Περιοχή (Γεωγ. Πλάτος) <i>Location (latitude)</i>	Q _d MJ	Q _L MJ	f _{sol} %
Stockholm (59.2° N)	4478	2148	48.1
Wuerzburg (49.5° N)	4289	2208	51.6
Davos (46.5° N)	4857	3185	65.9
Athens (38.0° N)	3343	2725	81.8

Performance indicators for solar-only systems on annual base for a demand value of 110 l d⁻¹

Περιοχή (Γεωγ. Πλάτος) <i>Location (latitude)</i>	Q _d MJ	Q _L MJ	f _{sol} %
Stockholm (59.2° N)	6150	2545	41.5
Wuerzburg (49.5° N)	5897	2658	45.2
Davos (46.5° N)	6654	3721	56.0
Athens (38.0° N)	4573	3406	74.6

Performance indicators for solar-only systems on annual base for a demand value of 140 l d⁻¹

Περιοχή (Γεωγ. Πλάτος) <i>Location (latitude)</i>	Q _d MJ	Q _L MJ	f _{sol} %
Stockholm (59.2° N)	7821	2778	35.5
Wuerzburg (49.5° N)	7506	2968	39.6
Davos (46.5° N)	8483	4100	48.3
Athens (38.0° N)	5834	3974	68.0

Performance indicators for solar-only systems on annual base for a demand value of 170 l d⁻¹

Περιοχή (Γεωγ. Πλάτος) <i>Location (latitude)</i>	Q _d MJ	Q _L MJ	f _{sol} %
Stockholm (59.2° N)	9492	2933	30.9
Wuerzburg (49.5° N)	9114	3185	35.0
Davos (46.5° N)	10281	4352	42.3
Athens (38.0° N)	7064	4384	62.1

Performance indicators for solar-only systems on annual base for a demand value of 200 l d⁻¹

Περιοχή (Γεωγ. Πλάτος) <i>Location (latitude)</i>	Q _d MJ	Q _L MJ	f _{sol} %
Stockholm (59.2° N)	11164	3034	27.2
Wuerzburg (49.5° N)	10691	3311	31.0
Davos (46.5° N)	12110	4510	37.3
Athens (38.0° N)	8326	4699	56.3

Performance indicators for solar-only systems on annual base for a demand value of 250 l d⁻¹

Περιοχή (Γεωγ. Πλάτος) <i>Location (latitude)</i>	Q _d MJ	Q _L MJ	f _{sol} %
Stockholm (59.2° N)	13939	3185	22.8
Wuerzburg (49.5° N)	13371	3406	25.5
Davos (46.5° N)	15137	4604	30.4
Athens (38.0° N)	10407	4857	46.7

Performance indicators for solar-only systems on annual base for a demand value of 300 l d⁻¹

Περιοχή (Γεωγ. Πλάτος) <i>Location (latitude)</i>	Q _d MJ	Q _L MJ	f _{sol} %
Stockholm (59.2° N)	16746	3280	19.6
Wuerzburg (49.5° N)	16052	3500	21.9
Davos (46.5° N)	18165	4699	25.9
Athens (38.0° N)	12488	5014	40.2

Performance indicators for solar-only systems on annual base for a demand value of 400 l d⁻¹

Περιοχή (Γεωγ. Πλάτος) <i>Location (latitude)</i>	Q _d MJ	Q _L MJ	f _{sol} %
Stockholm (59.2° N)	22327	3343	15.0
Wuerzburg (49.5° N)	21413	3564	16.6
Davos (46.5° N)	24220	4762	19.6
Athens (38.0° N)	16651	5077	30.4

Performance indicators for solar-only systems on annual base for a demand value of 600 l d⁻¹

Περιοχή (Γεωγ. Πλάτος) <i>Location (latitude)</i>	Q _d MJ	Q _L MJ	f _{sol} %
Stockholm (59.2° N)	33428	3374	10.1
Wuerzburg (49.5° N)	32167	3595	11.2
Davos (46.5° N)	36266	4793	13.2
Athens (38.0° N)	24945	5109	20.5

Model 150-1-S230*Performance indicators for solar-only systems on annual base for a demand value of 50 l d⁻¹*

Περιοχή (Γεωγ. Πλάτος) <i>Location (latitude)</i>	Q _d MJ	Q _L MJ	f _{sol} %
Stockholm (59.2° N)	2791	1678	60.1
Wuerzburg (49.5° N)	2677	1684	62.9
Davos (46.5° N)	3027	2526	83.4
Athens (38.0° N)	2078	1933	92.9

Performance indicators for solar-only systems on annual base for a demand value of 80 l d⁻¹

Περιοχή (Γεωγ. Πλάτος) <i>Location (latitude)</i>	Q _d MJ	Q _L MJ	f _{sol} %
Stockholm (59.2° N)	4478	2296	51.4
Wuerzburg (49.5° N)	4289	2343	54.7
Davos (46.5° N)	4857	3437	71.1
Athens (38.0° N)	3343	2829	85.0

Performance indicators for solar-only systems on annual base for a demand value of 110 l d⁻¹

Περιοχή (Γεωγ. Πλάτος) <i>Location (latitude)</i>	Q _d MJ	Q _L MJ	f _{sol} %
Stockholm (59.2° N)	6150	2763	45.0
Wuerzburg (49.5° N)	5897	2867	48.7
Davos (46.5° N)	6654	4100	61.5
Athens (38.0° N)	4573	3595	78.5

Performance indicators for solar-only systems on annual base for a demand value of 140 l d⁻¹

Περιοχή (Γεωγ. Πλάτος) <i>Location (latitude)</i>	Q _d MJ	Q _L MJ	f _{sol} %
Stockholm (59.2° N)	7821	3046	39.0
Wuerzburg (49.5° N)	7506	3248	43.3
Davos (46.5° N)	8483	4541	53.5
Athens (38.0° N)	5834	4226	72.3

Performance indicators for solar-only systems on annual base for a demand value of 170 l d⁻¹

Περιοχή (Γεωγ. Πλάτος) <i>Location (latitude)</i>	Q _d MJ	Q _L MJ	f _{sol} %
Stockholm (59.2° N)	9492	3248	34.1
Wuerzburg (49.5° N)	9114	3500	38.6
Davos (46.5° N)	10281	4857	47.1
Athens (38.0° N)	7064	4699	66.6

Performance indicators for solar-only systems on annual base for a demand value of 200 l d⁻¹

Περιοχή (Γεωγ. Πλάτος) <i>Location (latitude)</i>	Q _d MJ	Q _L MJ	f _{sol} %
Stockholm (59.2° N)	11164	3374	30.1
Wuerzburg (49.5° N)	10691	3658	34.3
Davos (46.5° N)	12110	5046	41.6
Athens (38.0° N)	8326	5077	61.1

Performance indicators for solar-only systems on annual base for a demand value of 250 l d⁻¹

Περιοχή (Γεωγ. Πλάτος) <i>Location (latitude)</i>	Q _d MJ	Q _L MJ	f _{sol} %
Stockholm (59.2° N)	13939	3532	25.3
Wuerzburg (49.5° N)	13371	3784	28.3
Davos (46.5° N)	15137	5172	34.1
Athens (38.0° N)	10407	5361	51.6

Performance indicators for solar-only systems on annual base for a demand value of 300 l d⁻¹

Περιοχή (Γεωγ. Πλάτος) <i>Location (latitude)</i>	Q _d MJ	Q _L MJ	f _{sol} %
Stockholm (59.2° N)	16746	3658	21.9
Wuerzburg (49.5° N)	16052	3910	24.4
Davos (46.5° N)	18165	5298	29.1
Athens (38.0° N)	12488	5582	44.6

Performance indicators for solar-only systems on annual base for a demand value of 400 l d⁻¹

Περιοχή (Γεωγ. Πλάτος) <i>Location (latitude)</i>	Q _d MJ	Q _L MJ	f _{sol} %
Stockholm (59.2° N)	22327	3721	16.7
Wuerzburg (49.5° N)	21413	3974	18.5
Davos (46.5° N)	24220	5361	22.1
Athens (38.0° N)	16651	5645	34.0

Performance indicators for solar-only systems on annual base for a demand value of 600 l d⁻¹

Περιοχή (Γεωγ. Πλάτος) <i>Location (latitude)</i>	Q _d MJ	Q _L MJ	f _{sol} %
Stockholm (59.2° N)	33428	3784	11.3
Wuerzburg (49.5° N)	32167	4005	12.5
Davos (46.5° N)	36266	5393	14.8
Athens (38.0° N)	24945	5708	22.9

Model 150-2-S150*Performance indicators for solar-only systems on annual base for a demand value of 50 l d⁻¹*

Περιοχή (Γεωγ. Πλάτος) Location (latitude)	Q _d MJ	Q _L MJ	f _{sol} %
Stockholm (59.2° N)	2791	1750	62.7
Wuerzburg (49.5° N)	2677	1750	65.3
Davos (46.5° N)	3027	2624	86.7
Athens (38.0° N)	2078	1968	94.7

Performance indicators for solar-only systems on annual base for a demand value of 80 l d⁻¹

Περιοχή (Γεωγ. Πλάτος) Location (latitude)	Q _d MJ	Q _L MJ	f _{sol} %
Stockholm (59.2° N)	4478	2435	54.5
Wuerzburg (49.5° N)	4289	2469	57.7
Davos (46.5° N)	4857	3658	75.7
Athens (38.0° N)	3343	2923	87.8

Performance indicators for solar-only systems on annual base for a demand value of 110 l d⁻¹

Περιοχή (Γεωγ. Πλάτος) Location (latitude)	Q _d MJ	Q _L MJ	f _{sol} %
Stockholm (59.2° N)	6150	2980	48.6
Wuerzburg (49.5° N)	5897	3062	52.0
Davos (46.5° N)	6654	4447	66.9
Athens (38.0° N)	4573	3753	82.0

Performance indicators for solar-only systems on annual base for a demand value of 140 l d⁻¹

Περιοχή (Γεωγ. Πλάτος) Location (latitude)	Q _d MJ	Q _L MJ	f _{sol} %
Stockholm (59.2° N)	7821	3311	42.6
Wuerzburg (49.5° N)	7506	3532	47.0
Davos (46.5° N)	8483	5014	59.0
Athens (38.0° N)	5834	4447	76.4

Performance indicators for solar-only systems on annual base for a demand value of 170 l d⁻¹

Περιοχή (Γεωγ. Πλάτος) Location (latitude)	Q _d MJ	Q _L MJ	f _{sol} %
Stockholm (59.2° N)	9492	3564	37.6
Wuerzburg (49.5° N)	9114	3879	42.5
Davos (46.5° N)	10281	5393	52.3
Athens (38.0° N)	7064	5014	71.1

Performance indicators for solar-only systems on annual base for a demand value of 200 l d⁻¹

Περιοχή (Γεωγ. Πλάτος) Location (latitude)	Q _d MJ	Q _L MJ	f _{sol} %
Stockholm (59.2° N)	11164	3721	33.3
Wuerzburg (49.5° N)	10691	4037	37.8
Davos (46.5° N)	12110	5613	46.4
Athens (38.0° N)	8326	5487	65.8

Performance indicators for solar-only systems on annual base for a demand value of 250 l d⁻¹

Περιοχή (Γεωγ. Πλάτος) Location (latitude)	Q _d MJ	Q _L MJ	f _{sol} %
Stockholm (59.2° N)	13939	3942	28.2
Wuerzburg (49.5° N)	13371	4226	31.5
Davos (46.5° N)	15137	5771	38.1
Athens (38.0° N)	10407	5897	56.7

Performance indicators for solar-only systems on annual base for a demand value of 300 l d⁻¹

Περιοχή (Γεωγ. Πλάτος) Location (latitude)	Q _d MJ	Q _L MJ	f _{sol} %
Stockholm (59.2° N)	16746	4068	24.4
Wuerzburg (49.5° N)	16052	4352	27.2
Davos (46.5° N)	18165	5929	32.7
Athens (38.0° N)	12488	6181	49.6

Performance indicators for solar-only systems on annual base for a demand value of 400 l d⁻¹

Περιοχή (Γεωγ. Πλάτος) Location (latitude)	Q _d MJ	Q _L MJ	f _{sol} %
Stockholm (59.2° N)	22327	4163	18.7
Wuerzburg (49.5° N)	21413	4447	20.7
Davos (46.5° N)	24220	6023	24.8
Athens (38.0° N)	16651	6307	37.9

Performance indicators for solar-only systems on annual base for a demand value of 600 l d⁻¹

Περιοχή (Γεωγ. Πλάτος) Location (latitude)	Q _d MJ	Q _L MJ	f _{sol} %
Stockholm (59.2° N)	33428	4226	12.6
Wuerzburg (49.5° N)	32167	4478	13.9
Davos (46.5° N)	36266	6055	16.6
Athens (38.0° N)	24945	6402	25.6

Model 200-1-S200*Performance indicators for solar-only systems on annual base for a demand value of 50 l d⁻¹*

Περιοχή (Γεωγ. Πλάτος) Location (latitude)	Q _d MJ	Q _L MJ	f _{sol} %
Stockholm (59.2° N)	2791	1589	56.9
Wuerzburg (49.5° N)	2677	1608	60.1
Davos (46.5° N)	3027	2397	79.1
Athens (38.0° N)	2078	1886	90.7

Performance indicators for solar-only systems on annual base for a demand value of 80 l d⁻¹

Περιοχή (Γεωγ. Πλάτος) Location (latitude)	Q _d MJ	Q _L MJ	f _{sol} %
Stockholm (59.2° N)	4478	2182	48.9
Wuerzburg (49.5° N)	4289	2274	53.1
Davos (46.5° N)	4857	3311	68.1
Athens (38.0° N)	3343	2794	83.9

Performance indicators for solar-only systems on annual base for a demand value of 110 l d⁻¹

Περιοχή (Γεωγ. Πλάτος) Location (latitude)	Q _d MJ	Q _L MJ	f _{sol} %
Stockholm (59.2° N)	6150	2554	41.6
Wuerzburg (49.5° N)	5897	2665	45.3
Davos (46.5° N)	6654	3721	55.9
Athens (38.0° N)	4573	3406	74.8

Performance indicators for solar-only systems on annual base for a demand value of 140 l d⁻¹

Περιοχή (Γεωγ. Πλάτος) Location (latitude)	Q _d MJ	Q _L MJ	f _{sol} %
Stockholm (59.2° N)	7821	2804	35.9
Wuerzburg (49.5° N)	7506	2986	39.9
Davos (46.5° N)	8483	4100	48.3
Athens (38.0° N)	5834	3974	68.3

Performance indicators for solar-only systems on annual base for a demand value of 170 l d⁻¹

Περιοχή (Γεωγ. Πλάτος) Location (latitude)	Q _d MJ	Q _L MJ	f _{sol} %
Stockholm (59.2° N)	9492	2980	31.4
Wuerzburg (49.5° N)	9114	3217	35.4
Davos (46.5° N)	10281	4384	42.5
Athens (38.0° N)	7064	4415	62.6

Performance indicators for solar-only systems on annual base for a demand value of 200 l d⁻¹

Περιοχή (Γεωγ. Πλάτος) Location (latitude)	Q _d MJ	Q _L MJ	f _{sol} %
Stockholm (59.2° N)	11164	3106	27.8
Wuerzburg (49.5° N)	10691	3406	31.8
Davos (46.5° N)	12110	4573	37.8
Athens (38.0° N)	8326	4762	57.4

Performance indicators for solar-only systems on annual base for a demand value of 250 l d⁻¹

Περιοχή (Γεωγ. Πλάτος) Location (latitude)	Q _d MJ	Q _L MJ	f _{sol} %
Stockholm (59.2° N)	13939	3280	23.4
Wuerzburg (49.5° N)	13371	3500	26.1
Davos (46.5° N)	15137	4699	31.0
Athens (38.0° N)	10407	4983	47.9

Performance indicators for solar-only systems on annual base for a demand value of 300 l d⁻¹

Περιοχή (Γεωγ. Πλάτος) Location (latitude)	Q _d MJ	Q _L MJ	f _{sol} %
Stockholm (59.2° N)	16746	3406	20.3
Wuerzburg (49.5° N)	16052	3627	22.6
Davos (46.5° N)	18165	4825	26.6
Athens (38.0° N)	12488	5172	41.5

Performance indicators for solar-only systems on annual base for a demand value of 400 l d⁻¹

Περιοχή (Γεωγ. Πλάτος) Location (latitude)	Q _d MJ	Q _L MJ	f _{sol} %
Stockholm (59.2° N)	22327	3500	15.6
Wuerzburg (49.5° N)	21413	3753	17.5
Davos (46.5° N)	24220	4983	20.5
Athens (38.0° N)	16651	5330	32.0

Performance indicators for solar-only systems on annual base for a demand value of 600 l d⁻¹

Περιοχή (Γεωγ. Πλάτος) Location (latitude)	Q _d MJ	Q _L MJ	f _{sol} %
Stockholm (59.2° N)	33428	3564	10.6
Wuerzburg (49.5° N)	32167	3784	11.8
Davos (46.5° N)	36266	4983	13.7
Athens (38.0° N)	24945	5393	21.6

Model 200-1-S230*Performance indicators for solar-only systems on annual base for a demand value of 50 l d⁻¹*

Περιοχή (Γεωγ. Πλάτος) <i>Location (latitude)</i>	Q _d MJ	Q _L MJ	f _{sol} %
Stockholm (59.2° N)	2791	1668	59.8
Wuerzburg (49.5° N)	2677	1681	62.8
Davos (46.5° N)	3027	2517	83.1
Athens (38.0° N)	2078	1933	93.0

Performance indicators for solar-only systems on annual base for a demand value of 80 l d⁻¹

Περιοχή (Γεωγ. Πλάτος) <i>Location (latitude)</i>	Q _d MJ	Q _L MJ	f _{sol} %
Stockholm (59.2° N)	4478	2340	52.4
Wuerzburg (49.5° N)	4289	2406	56.2
Davos (46.5° N)	4857	3564	73.5
Athens (38.0° N)	3343	2901	87.2

Performance indicators for solar-only systems on annual base for a demand value of 110 l d⁻¹

Περιοχή (Γεωγ. Πλάτος) <i>Location (latitude)</i>	Q _d MJ	Q _L MJ	f _{sol} %
Stockholm (59.2° N)	6150	2785	45.3
Wuerzburg (49.5° N)	5897	2886	49.0
Davos (46.5° N)	6654	4100	61.7
Athens (38.0° N)	4573	3627	79.0

Performance indicators for solar-only systems on annual base for a demand value of 140 l d⁻¹

Περιοχή (Γεωγ. Πλάτος) <i>Location (latitude)</i>	Q _d MJ	Q _L MJ	f _{sol} %
Stockholm (59.2° N)	7821	3091	39.5
Wuerzburg (49.5° N)	7506	3280	43.8
Davos (46.5° N)	8483	4573	53.9
Athens (38.0° N)	5834	4257	73.0

Performance indicators for solar-only systems on annual base for a demand value of 170 l d⁻¹

Περιοχή (Γεωγ. Πλάτος) <i>Location (latitude)</i>	Q _d MJ	Q _L MJ	f _{sol} %
Stockholm (59.2° N)	9492	3311	34.8
Wuerzburg (49.5° N)	9114	3564	39.2
Davos (46.5° N)	10281	4920	47.7
Athens (38.0° N)	7064	4762	67.4

Performance indicators for solar-only systems on annual base for a demand value of 200 l d⁻¹

Περιοχή (Γεωγ. Πλάτος) <i>Location (latitude)</i>	Q _d MJ	Q _L MJ	f _{sol} %
Stockholm (59.2° N)	11164	3469	31.0
Wuerzburg (49.5° N)	10691	3784	35.3
Davos (46.5° N)	12110	5172	42.6
Athens (38.0° N)	8326	5203	62.4

Performance indicators for solar-only systems on annual base for a demand value of 250 l d⁻¹

Περιοχή (Γεωγ. Πλάτος) <i>Location (latitude)</i>	Q _d MJ	Q _L MJ	f _{sol} %
Stockholm (59.2° N)	13939	3658	26.2
Wuerzburg (49.5° N)	13371	3910	29.2
Davos (46.5° N)	15137	5298	35.0
Athens (38.0° N)	10407	5550	53.2

Performance indicators for solar-only systems on annual base for a demand value of 300 l d⁻¹

Περιοχή (Γεωγ. Πλάτος) <i>Location (latitude)</i>	Q _d MJ	Q _L MJ	f _{sol} %
Stockholm (59.2° N)	16746	3816	22.7
Wuerzburg (49.5° N)	16052	4068	25.3
Davos (46.5° N)	18165	5487	30.1
Athens (38.0° N)	12488	5803	46.4

Performance indicators for solar-only systems on annual base for a demand value of 400 l d⁻¹

Περιοχή (Γεωγ. Πλάτος) <i>Location (latitude)</i>	Q _d MJ	Q _L MJ	f _{sol} %
Stockholm (59.2° N)	22327	3942	17.6
Wuerzburg (49.5° N)	21413	4226	19.7
Davos (46.5° N)	24220	5645	23.3
Athens (38.0° N)	16651	5992	36.0

Performance indicators for solar-only systems on annual base for a demand value of 600 l d⁻¹

Περιοχή (Γεωγ. Πλάτος) <i>Location (latitude)</i>	Q _d MJ	Q _L MJ	f _{sol} %
Stockholm (59.2° N)	33428	4005	12.0
Wuerzburg (49.5° N)	32167	4257	13.2
Davos (46.5° N)	36266	5676	15.6
Athens (38.0° N)	24945	6086	24.3

Model 200-1-S260*Performance indicators for solar-only systems on annual base for a demand value of 50 l d⁻¹*

Περιοχή (Γεωγ. Πλάτος) <i>Location (latitude)</i>	Q _d MJ	Q _L MJ	f _{sol} %
Stockholm (59.2° N)	2791	1659	59.4
Wuerzburg (49.5° N)	2677	1681	62.8
Davos (46.5° N)	3027	2479	81.8
Athens (38.0° N)	2078	1930	92.8

Performance indicators for solar-only systems on annual base for a demand value of 80 l d⁻¹

Περιοχή (Γεωγ. Πλάτος) <i>Location (latitude)</i>	Q _d MJ	Q _L MJ	f _{sol} %
Stockholm (59.2° N)	4478	2353	52.7
Wuerzburg (49.5° N)	4289	2394	55.9
Davos (46.5° N)	4857	3500	72.1
Athens (38.0° N)	3343	2879	86.6

Performance indicators for solar-only systems on annual base for a demand value of 110 l d⁻¹

Περιοχή (Γεωγ. Πλάτος) <i>Location (latitude)</i>	Q _d MJ	Q _L MJ	f _{sol} %
Stockholm (59.2° N)	6150	2800	45.6
Wuerzburg (49.5° N)	5897	2882	48.9
Davos (46.5° N)	6654	4068	61.1
Athens (38.0° N)	4573	3627	78.9

Performance indicators for solar-only systems on annual base for a demand value of 140 l d⁻¹

Περιοχή (Γεωγ. Πλάτος) <i>Location (latitude)</i>	Q _d MJ	Q _L MJ	f _{sol} %
Stockholm (59.2° N)	7821	3138	40.2
Wuerzburg (49.5° N)	7506	3280	43.9
Davos (46.5° N)	8483	4541	53.4
Athens (38.0° N)	5834	4257	72.9

Performance indicators for solar-only systems on annual base for a demand value of 170 l d⁻¹

Περιοχή (Γεωγ. Πλάτος) <i>Location (latitude)</i>	Q _d MJ	Q _L MJ	f _{sol} %
Stockholm (59.2° N)	9492	3374	35.7
Wuerzburg (49.5° N)	9114	3595	39.5
Davos (46.5° N)	10281	4857	47.1
Athens (38.0° N)	7064	4762	67.3

Performance indicators for solar-only systems on annual base for a demand value of 200 l d⁻¹

Περιοχή (Γεωγ. Πλάτος) <i>Location (latitude)</i>	Q _d MJ	Q _L MJ	f _{sol} %
Stockholm (59.2° N)	11164	3595	32.2
Wuerzburg (49.5° N)	10691	3816	35.7
Davos (46.5° N)	12110	5109	42.1
Athens (38.0° N)	8326	5172	62.3

Performance indicators for solar-only systems on annual base for a demand value of 250 l d⁻¹

Περιοχή (Γεωγ. Πλάτος) <i>Location (latitude)</i>	Q _d MJ	Q _L MJ	f _{sol} %
Stockholm (59.2° N)	13939	3784	27.2
Wuerzburg (49.5° N)	13371	4100	30.6
Davos (46.5° N)	15137	5361	35.5
Athens (38.0° N)	10407	5676	54.6

Performance indicators for solar-only systems on annual base for a demand value of 300 l d⁻¹

Περιοχή (Γεωγ. Πλάτος) <i>Location (latitude)</i>	Q _d MJ	Q _L MJ	f _{sol} %
Stockholm (59.2° N)	16746	3974	23.7
Wuerzburg (49.5° N)	16052	4289	26.6
Davos (46.5° N)	18165	5550	30.6
Athens (38.0° N)	12488	5960	47.9

Performance indicators for solar-only systems on annual base for a demand value of 400 l d⁻¹

Περιοχή (Γεωγ. Πλάτος) <i>Location (latitude)</i>	Q _d MJ	Q _L MJ	f _{sol} %
Stockholm (59.2° N)	22327	4163	18.7
Wuerzburg (49.5° N)	21413	4384	20.5
Davos (46.5° N)	24220	5645	23.3
Athens (38.0° N)	16651	6150	36.9

Performance indicators for solar-only systems on annual base for a demand value of 600 l d⁻¹

Περιοχή (Γεωγ. Πλάτος) <i>Location (latitude)</i>	Q _d MJ	Q _L MJ	f _{sol} %
Stockholm (59.2° N)	33428	4257	12.7
Wuerzburg (49.5° N)	32167	4478	14.0
Davos (46.5° N)	36266	5740	15.8
Athens (38.0° N)	24945	6307	25.3

Model 200-2-S200*Performance indicators for solar-only systems on annual base for a demand value of 50 l d⁻¹*

Περιοχή (Γεωγ. Πλάτος) Location (latitude)	Q _d MJ	Q _L MJ	f _{sol} %
Stockholm (59.2° N)	2791	1798	64.4
Wuerzburg (49.5° N)	2677	1801	67.2
Davos (46.5° N)	3027	2693	88.9
Athens (38.0° N)	2078	1999	96.1

Performance indicators for solar-only systems on annual base for a demand value of 80 l d⁻¹

Περιοχή (Γεωγ. Πλάτος) Location (latitude)	Q _d MJ	Q _L MJ	f _{sol} %
Stockholm (59.2° N)	4478	2599	58.2
Wuerzburg (49.5° N)	4289	2630	61.4
Davos (46.5° N)	4857	3942	81.4
Athens (38.0° N)	3343	3050	91.6

Performance indicators for solar-only systems on annual base for a demand value of 110 l d⁻¹

Περιοχή (Γεωγ. Πλάτος) Location (latitude)	Q _d MJ	Q _L MJ	f _{sol} %
Stockholm (59.2° N)	6150	3185	51.7
Wuerzburg (49.5° N)	5897	3248	54.9
Davos (46.5° N)	6654	4762	71.5
Athens (38.0° N)	4573	3879	85.1

Performance indicators for solar-only systems on annual base for a demand value of 140 l d⁻¹

Περιοχή (Γεωγ. Πλάτος) Location (latitude)	Q _d MJ	Q _L MJ	f _{sol} %
Stockholm (59.2° N)	7821	3595	46.1
Wuerzburg (49.5° N)	7506	3784	50.3
Davos (46.5° N)	8483	5456	64.2
Athens (38.0° N)	5834	4667	80.2

Performance indicators for solar-only systems on annual base for a demand value of 170 l d⁻¹

Περιοχή (Γεωγ. Πλάτος) Location (latitude)	Q _d MJ	Q _L MJ	f _{sol} %
Stockholm (59.2° N)	9492	3910	41.3
Wuerzburg (49.5° N)	9114	4194	46.1
Davos (46.5° N)	10281	5929	57.6
Athens (38.0° N)	7064	5330	75.4

Performance indicators for solar-only systems on annual base for a demand value of 200 l d⁻¹

Περιοχή (Γεωγ. Πλάτος) Location (latitude)	Q _d MJ	Q _L MJ	f _{sol} %
Stockholm (59.2° N)	11164	4131	37.1
Wuerzburg (49.5° N)	10691	4510	42.2
Davos (46.5° N)	12110	6307	52.0
Athens (38.0° N)	8326	5897	70.9

Performance indicators for solar-only systems on annual base for a demand value of 250 l d⁻¹

Περιοχή (Γεωγ. Πλάτος) Location (latitude)	Q _d MJ	Q _L MJ	f _{sol} %
Stockholm (59.2° N)	13939	4415	31.7
Wuerzburg (49.5° N)	13371	4730	35.3
Davos (46.5° N)	15137	6528	43.1
Athens (38.0° N)	10407	6496	62.3

Performance indicators for solar-only systems on annual base for a demand value of 300 l d⁻¹

Περιοχή (Γεωγ. Πλάτος) Location (latitude)	Q _d MJ	Q _L MJ	f _{sol} %
Stockholm (59.2° N)	16746	4636	27.7
Wuerzburg (49.5° N)	16052	4951	30.8
Davos (46.5° N)	18165	6780	37.3
Athens (38.0° N)	12488	6969	55.8

Performance indicators for solar-only systems on annual base for a demand value of 400 l d⁻¹

Περιοχή (Γεωγ. Πλάτος) Location (latitude)	Q _d MJ	Q _L MJ	f _{sol} %
Stockholm (59.2° N)	22327	4825	21.6
Wuerzburg (49.5° N)	21413	5172	24.1
Davos (46.5° N)	24220	7001	29.0
Athens (38.0° N)	16651	7316	44.0

Performance indicators for solar-only systems on annual base for a demand value of 600 l d⁻¹

Περιοχή (Γεωγ. Πλάτος) Location (latitude)	Q _d MJ	Q _L MJ	f _{sol} %
Stockholm (59.2° N)	33428	4920	14.7
Wuerzburg (49.5° N)	32167	5235	16.3
Davos (46.5° N)	36266	7096	19.5
Athens (38.0° N)	24945	7474	29.9

Model 300-2-S200*Performance indicators for solar-only systems on annual base for a demand value of 50 l d⁻¹*

Περιοχή (Γεωγ. Πλάτος) Location (latitude)	Q _d MJ	Q _L MJ	f _{sol} %
Stockholm (59.2° N)	2791	1857	66.6
Wuerzburg (49.5° N)	2677	1876	70.1
Davos (46.5° N)	3027	2778	91.8
Athens (38.0° N)	2078	2034	97.9

Performance indicators for solar-only systems on annual base for a demand value of 80 l d⁻¹

Περιοχή (Γεωγ. Πλάτος) Location (latitude)	Q _d MJ	Q _L MJ	f _{sol} %
Stockholm (59.2° N)	4478	2763	61.9
Wuerzburg (49.5° N)	4289	2781	64.9
Davos (46.5° N)	4857	4163	86.0
Athens (38.0° N)	3343	3150	94.7

Performance indicators for solar-only systems on annual base for a demand value of 110 l d⁻¹

Περιοχή (Γεωγ. Πλάτος) Location (latitude)	Q _d MJ	Q _L MJ	f _{sol} %
Stockholm (59.2° N)	6150	3564	57.8
Wuerzburg (49.5° N)	5897	3595	60.8
Davos (46.5° N)	6654	5361	80.3
Athens (38.0° N)	4573	4163	91.1

Performance indicators for solar-only systems on annual base for a demand value of 140 l d⁻¹

Περιοχή (Γεωγ. Πλάτος) Location (latitude)	Q _d MJ	Q _L MJ	f _{sol} %
Stockholm (59.2° N)	7821	4131	52.7
Wuerzburg (49.5° N)	7506	4163	55.6
Davos (46.5° N)	8483	6118	72.1
Athens (38.0° N)	5834	4983	85.8

Performance indicators for solar-only systems on annual base for a demand value of 170 l d⁻¹

Περιοχή (Γεωγ. Πλάτος) Location (latitude)	Q _d MJ	Q _L MJ	f _{sol} %
Stockholm (59.2° N)	9492	4573	48.3
Wuerzburg (49.5° N)	9114	4730	51.9
Davos (46.5° N)	10281	6812	66.3
Athens (38.0° N)	7064	5803	82.0

Performance indicators for solar-only systems on annual base for a demand value of 200 l d⁻¹

Περιοχή (Γεωγ. Πλάτος) Location (latitude)	Q _d MJ	Q _L MJ	f _{sol} %
Stockholm (59.2° N)	11164	4983	44.7
Wuerzburg (49.5° N)	10691	5203	48.6
Davos (46.5° N)	12110	7379	61.0
Athens (38.0° N)	8326	6528	78.4

Performance indicators for solar-only systems on annual base for a demand value of 250 l d⁻¹

Περιοχή (Γεωγ. Πλάτος) Location (latitude)	Q _d MJ	Q _L MJ	f _{sol} %
Stockholm (59.2° N)	13939	5456	39.1
Wuerzburg (49.5° N)	13371	5803	43.5
Davos (46.5° N)	15137	8105	53.5
Athens (38.0° N)	10407	7537	72.5

Performance indicators for solar-only systems on annual base for a demand value of 300 l d⁻¹

Περιοχή (Γεωγ. Πλάτος) Location (latitude)	Q _d MJ	Q _L MJ	f _{sol} %
Stockholm (59.2° N)	16746	5771	34.5
Wuerzburg (49.5° N)	16052	6276	39.0
Davos (46.5° N)	18165	8641	47.5
Athens (38.0° N)	12488	8389	67.2

Performance indicators for solar-only systems on annual base for a demand value of 400 l d⁻¹

Περιοχή (Γεωγ. Πλάτος) Location (latitude)	Q _d MJ	Q _L MJ	f _{sol} %
Stockholm (59.2° N)	22327	6307	28.2
Wuerzburg (49.5° N)	21413	6686	31.3
Davos (46.5° N)	24220	9177	37.9
Athens (38.0° N)	16651	9429	56.6

Performance indicators for solar-only systems on annual base for a demand value of 600 l d⁻¹

Περιοχή (Γεωγ. Πλάτος) Location (latitude)	Q _d MJ	Q _L MJ	f _{sol} %
Stockholm (59.2° N)	33428	6686	20.0
Wuerzburg (49.5° N)	32167	7033	21.9
Davos (46.5° N)	36266	9524	26.2
Athens (38.0° N)	24945	10092	40.5

Model 300-2-S230
Performance indicators for solar-only systems on annual base for a demand value of 50 l d⁻¹

Περιοχή (Γεωγ. Πλάτος)	Q _d	Q _L	f _{sol}
Location (latitude)	MJ	MJ	%
Stockholm (59.2° N)	2791	1911	68.5
Wuerzburg (49.5° N)	2677	1927	72.0
Davos (46.5° N)	3027	2829	93.5
Athens (38.0° N)	2078	2050	98.6

Performance indicators for solar-only systems on annual base for a demand value of 80 l d⁻¹

Περιοχή (Γεωγ. Πλάτος)	Q _d	Q _L	f _{sol}
Location (latitude)	MJ	MJ	%
Stockholm (59.2° N)	4478	2860	64.1
Wuerzburg (49.5° N)	4289	2873	67.1
Davos (46.5° N)	4857	4289	88.7
Athens (38.0° N)	3343	3185	96.1

Performance indicators for solar-only systems on annual base for a demand value of 110 l d⁻¹

Περιοχή (Γεωγ. Πλάτος)	Q _d	Q _L	f _{sol}
Location (latitude)	MJ	MJ	%
Stockholm (59.2° N)	6150	3690	60.3
Wuerzburg (49.5° N)	5897	3721	63.2
Davos (46.5° N)	6654	5582	83.8
Athens (38.0° N)	4573	4257	93.0

Performance indicators for solar-only systems on annual base for a demand value of 140 l d⁻¹

Περιοχή (Γεωγ. Πλάτος)	Q _d	Q _L	f _{sol}
Location (latitude)	MJ	MJ	%
Stockholm (59.2° N)	7821	4352	55.5
Wuerzburg (49.5° N)	7506	4352	58.3
Davos (46.5° N)	8483	6465	76.4
Athens (38.0° N)	5834	5140	88.4

Performance indicators for solar-only systems on annual base for a demand value of 170 l d⁻¹

Περιοχή (Γεωγ. Πλάτος)	Q _d	Q _L	f _{sol}
Location (latitude)	MJ	MJ	%
Stockholm (59.2° N)	9492	4888	51.4
Wuerzburg (49.5° N)	9114	4983	54.8
Davos (46.5° N)	10281	7316	71.1
Athens (38.0° N)	7064	6023	85.0

Performance indicators for solar-only systems on annual base for a demand value of 200 l d⁻¹

Περιοχή (Γεωγ. Πλάτος)	Q _d	Q _L	f _{sol}
Location (latitude)	MJ	MJ	%
Stockholm (59.2° N)	11164	5330	47.9
Wuerzburg (49.5° N)	10691	5519	51.7
Davos (46.5° N)	12110	8010	66.2
Athens (38.0° N)	8326	6780	81.7

Performance indicators for solar-only systems on annual base for a demand value of 250 l d⁻¹

Περιοχή (Γεωγ. Πλάτος)	Q _d	Q _L	f _{sol}
Location (latitude)	MJ	MJ	%
Stockholm (59.2° N)	13939	5929	42.4
Wuerzburg (49.5° N)	13371	6276	46.9
Davos (46.5° N)	15137	8893	58.7
Athens (38.0° N)	10407	7947	76.4

Performance indicators for solar-only systems on annual base for a demand value of 300 l d⁻¹

Περιοχή (Γεωγ. Πλάτος)	Q _d	Q _L	f _{sol}
Location (latitude)	MJ	MJ	%
Stockholm (59.2° N)	16746	6307	37.7
Wuerzburg (49.5° N)	16052	6812	42.5
Davos (46.5° N)	18165	9524	52.4
Athens (38.0° N)	12488	8893	71.3

Performance indicators for solar-only systems on annual base for a demand value of 400 l d⁻¹

Περιοχή (Γεωγ. Πλάτος)	Q _d	Q _L	f _{sol}
Location (latitude)	MJ	MJ	%
Stockholm (59.2° N)	22327	6938	31.0
Wuerzburg (49.5° N)	21413	7348	34.4
Davos (46.5° N)	24220	10186	42.0
Athens (38.0° N)	16651	10155	61.1

Performance indicators for solar-only systems on annual base for a demand value of 600 l d⁻¹

Περιοχή (Γεωγ. Πλάτος)	Q _d	Q _L	f _{sol}
Location (latitude)	MJ	MJ	%
Stockholm (59.2° N)	33428	7411	22.1
Wuerzburg (49.5° N)	32167	7789	24.3
Davos (46.5° N)	36266	10628	29.2
Athens (38.0° N)	24945	11132	44.6

5. Flat roof

Assembly instructions for systems with 1 collector:

Models: 125-1-S150, 125-1-S200, 150-1-S200, 150-1-S230, 200-1-S200, 200-1-S230, 200-1-S260

Assembly steps:

- 5.1. Open the pack of the support system. Identify the items from table (page 5) and the drawing next page.
- 5.2. Assembly the parts between themselves using the set of bolts and nuts included in the pack. At this stage do not fasten tight the bolts.
- 5.3. Fix collector on support as shown on drawing using the M6X20mm bolts and washers (No. 22-23). Do not fasten tight yet.
- 5.4. Position the tank on supports. Two people are needed to handle it from each end. Fasten well with the 2 bolts M10X30 the tank on the support system. (The 2 bolts are already mounted on the tank and have to be temporarily removed before placing the tank on the support).
- 5.5. Now, fasten well the collector on support and then fasten well all the parts of the support system among themselves.
- 5.6. Drill the "floor" with 10mm drill at the 4 fixing points, insert the raw-plugs provided, and fasten well the whole support system to the "floor". Make sure that the material of "floor" is suitable (concrete) for this kind of fixing, in order to withstand up to 97,2 Km/hr wind speed. If in doubt, consult your supplier, or your engineer for possible alternative way of fixing.
- 5.7. Connect the insulated copper (or plastic) pipe at closed loop system. The long pipe is for cold return to bottom of collector. The short pipe is for hot supply from top of collector. Make sure that you fasten well the "compression" fittings in order to tight the closed loop.
- 5.8. Connect the non-return pressure safety valve on the cold water inlet of tank, making sure that the arrow is pointing towards the tank (upwards) and the escape outlet is facing sideways parallel to the tank.
- 5.9. Connect cold water supply using always a shut-off water valve. (Make sure the pipes are well insulated)
- 5.10. Connect hot water outlet piping to consumption points. It is strongly recommended to install a thermostatic mixing valve set at 55°C on the hot water piping anywhere before the consumption points. (Make sure the pipes are well insulated).
- 5.11. Fill the tank with cold water. Leave open one "tap" of hot water, so that air will be flushed out and the tank will be completely filled up.
- 5.12. Fill up the closed loop system with thermo-convention liquid from the top pipe (point 15). Make sure that no air-bubbles are coming out so filling is completed.
- 5.13. Screw the bronze cap with the copper ring on the filling point to seal the closed loop system. The closed loop is permanently sealed.
- 5.14. Check for leakages on open or closed loop system.
- 5.15. The (optional) electric heater should be connected by a fully licensed electrician following the national standards for electric installations.

Connections points on thermostat:

No 1 : Line L (220 volt)
No 4 : Neutral N

On metal flange:  ..: Earth

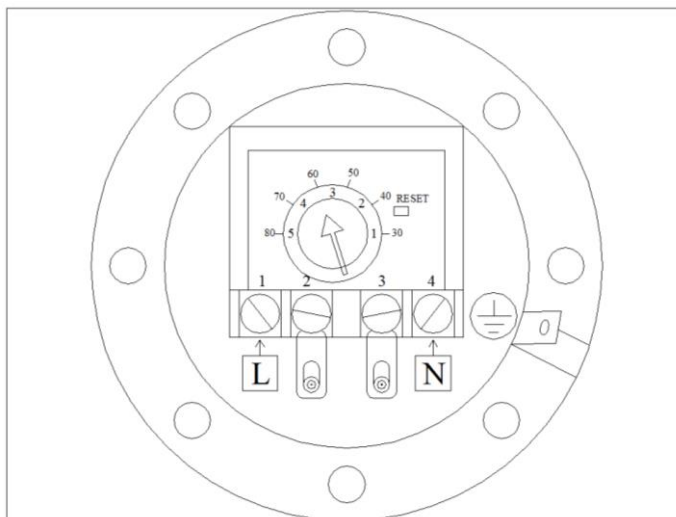

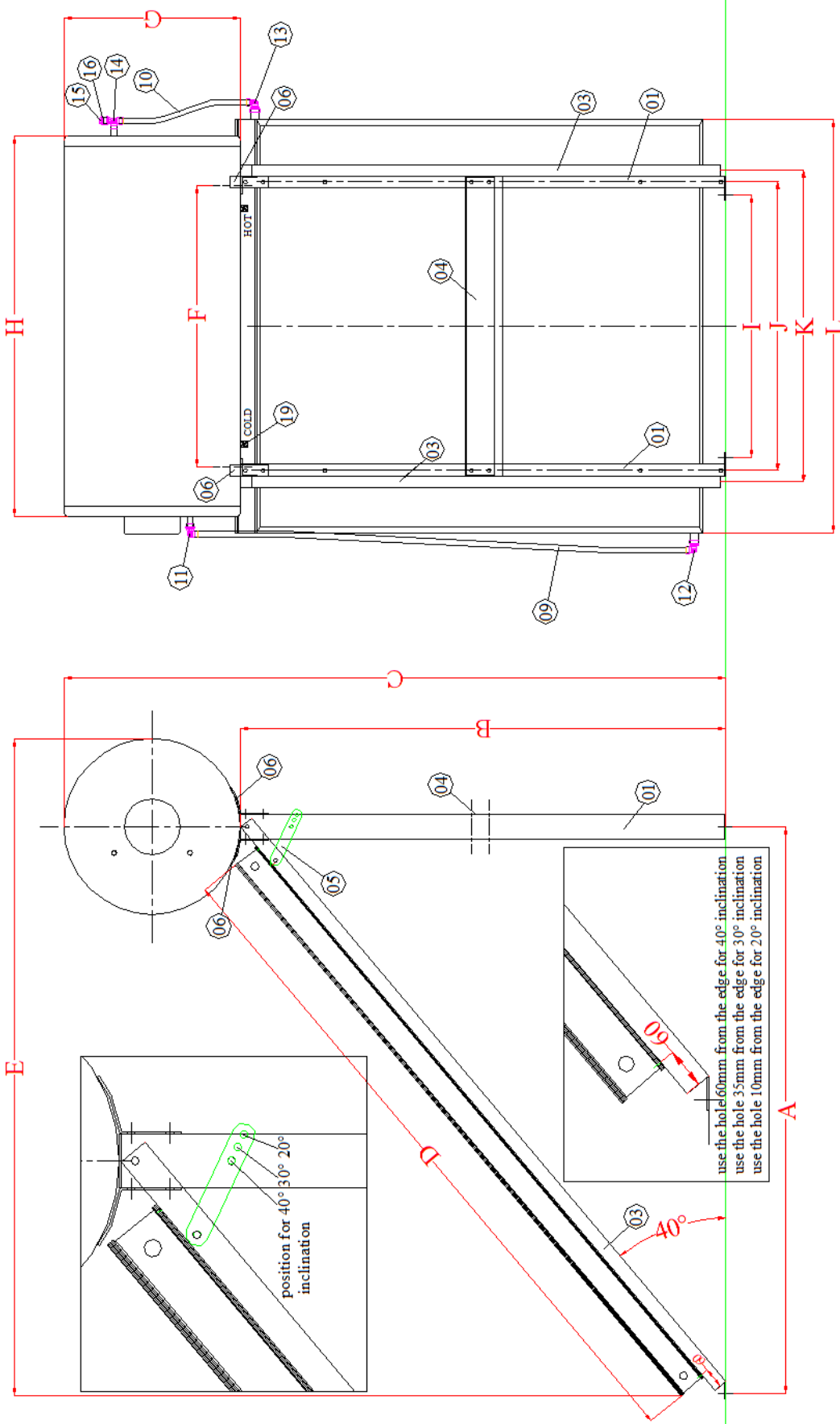

DIMENSION	ECO 125-1-150	ECO 125-1-200	ECO 150-1-200	ECO 150-1-230	ECO 200-1-200	ECO 200-1-230	ECO 200-1-260
A	1291mm	1613mm	1613mm	1613mm	1613mm	1613mm	1747mm
B	1107mm	1377mm	1377mm	1377mm	1377mm	1377mm	1489mm
C	1547mm	1817mm	1877mm	1877mm	1907mm	1907mm	2019mm
D	1540mm	1960mm	1960mm	1960mm	1960mm	1960mm	2135mm
E	1516mm	1838mm	1868mm	1868mm	1883mm	1883mm	2017mm
F	800mm	800mm	800mm	800mm	800mm	800mm	800mm
G	440mm	440mm	500mm	500mm	530mm	530mm	530mm
H	1060mm	1125mm	1125mm	1125mm	1125mm	1145mm	1145mm
I	745mm	745mm	745mm	745mm	745mm	745mm	745mm
J	820mm	820mm	820mm	820mm	820mm	820mm	820mm
K	895mm	895mm	895mm	895mm	895mm	895mm	895mm
L	960mm	960mm	960mm	960mm	960mm	1165mm	1238mm

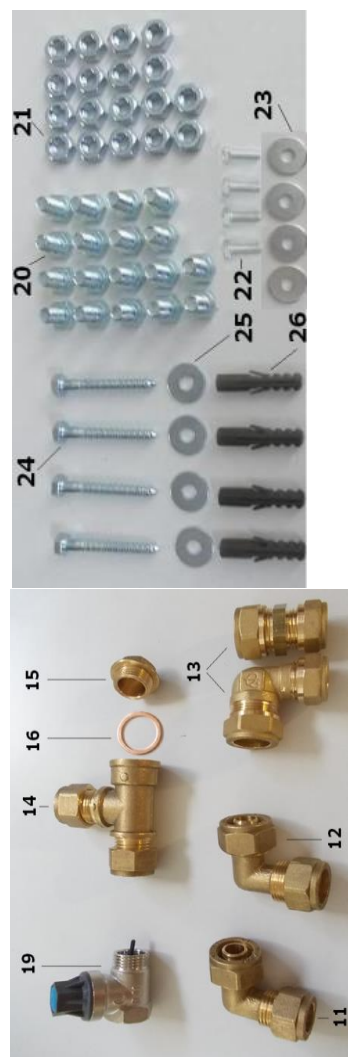

6. Flat roof

Assembly instructions for systems with 2 collectors:

Models: 150-2-S150, 200-2-S200, 300-2-S200, 300-2-S230

Assembly steps:

- 6.1. Open the pack of the support system. Identify the items from table (page 5) and the drawing next page.
- 6.2. Assembly the parts between themselves using the set of bolts and nuts included in the pack. At this stage do not fasten tight the bolts.
- 6.3. Fix collectors on support as shown on drawing using M6X20 bolts and washers (No 22 & 23 at table) Do not fasten tight yet.
- 6.4. Position the tank on supports. Two people for 200 ltr and four people for 300 ltr are needed to handle it from each end. Fasten well with the 2 bolts M10X30 the tank on the support system. (The 2 bolts are already mounted on the tank and have to be temporarily removed before placing the tank on the support).
- 6.5. Now, fasten well the collectors on support and then fasten well all the parts of the support system among themselves.
- 6.6. Drill the “floor” with 10mm drill at the 4 fixing points, insert the raw-plugs provided, and fasten well the whole support system to the “floor”. Make sure that the material of “floor” is suitable (concrete) for this kind of fixing, in order to withstand up to 97,2 Km/hr wind speed. If in doubt, consult your supplier, or your engineer for possible alternative way of fixing.
- 6.7. Connect the insulated copper (or plastic) pipe at closed loop system. The long pipe is for cold return to bottom of collector. The short pipe is for hot supply from top of collector. Make sure that you fasten well the “compression” fittings in order to tight the closed loop. Fix and fasten well the 2 compression end caps on the 2 remaining open ends of the collectors.
- 6.8. Connect the non-return pressure safety valve on the cold water inlet of boiler making sure that the arrow is pointing towards the tank (upwards) and the escape outlet is facing sideways parallel to the tank, in order to prevent harm or burning during steam escape.
- 6.9. Connect cold water supply using always a shut-off water valve. (Make sure the pipes are well insulated).
- 6.10. Connect hot water outlet piping to consumption points. It is strongly recommended to install a thermostatic mixing valve set at 50-55°C on the hot water piping anywhere before the consumption points. (Make sure the pipes are well insulated).
- 6.11. Fill the tank with cold water. Leave open one “tap” of hot water, so that air will be flushed out and the tank will be completely filled up.
- 6.12. Fill up the closed loop system with thermo-convention liquid from the top pipe (point 15). Make sure that no air-bubbles are coming out so filling is completed.
- 6.13. Screw the bronze cap with the copper ring on the filling point to seal the closed loop system. The closed loop is permanently sealed.
- 6.14. Check for leakages on open or closed loop system.
- 6.15. The (optional) electric heater should be connected by a fully licensed electrician following the national standards for electric installations.

Connections points on thermostat:

No 1 : Line L (220 volt)
No 4 : Neutral N

On metal flange:  : Earth

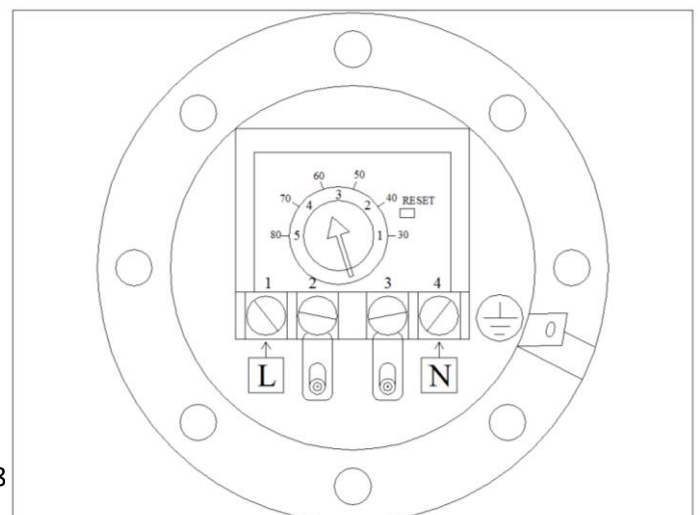

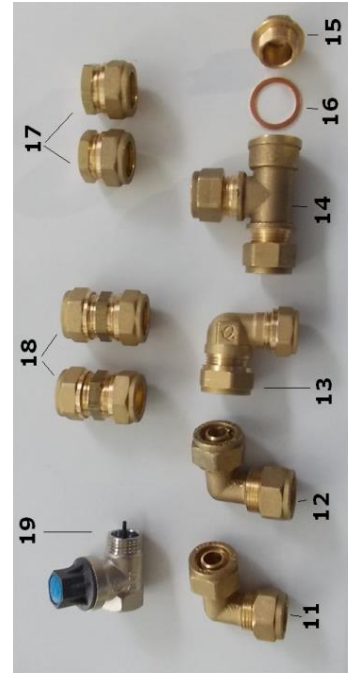
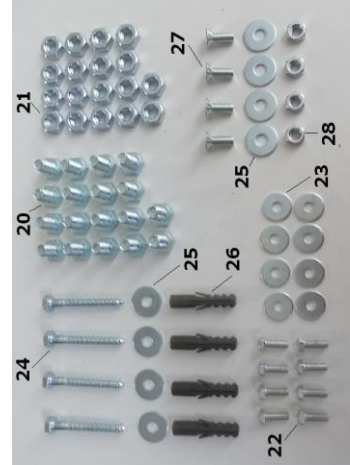
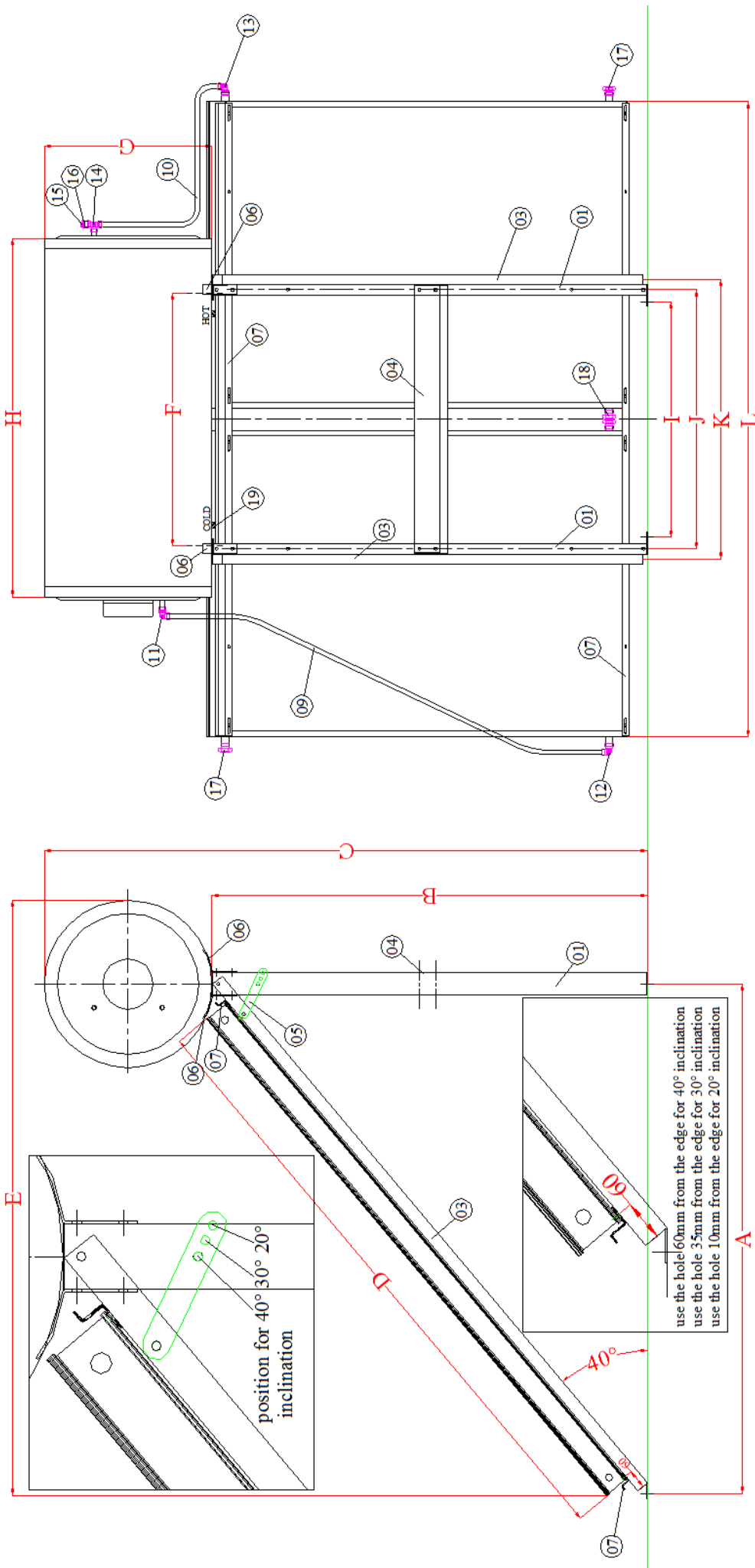

DIMENSION	ECO 150-2-150	ECO 200-2-200	ECO 300-2-200	ECO 300-2-230
A	1291mm	1613mm	1613mm	1613mm
B	1107mm	1377mm	1377mm	1377mm
C	1607mm	1907mm	1907mm	1907mm
D	1540mm	1960mm	1960mm	1960mm
E	1548mm	1884mm	1884mm	1884mm
F	800mm	800mm	1345mm	1345mm
G	500mm	530mm	530mm	530mm
H	1125mm	1145mm	1835mm	1835mm
I	745mm	745mm	1299mm	1299mm
J	820mm	820mm	1374mm	1374mm
K	895mm	895mm	1439mm	1439mm
L	2010mm	2010mm	2010mm	2420mm

7. Inclined roof - Tiles

Assembly instructions for systems with 1 collector:

Models: 125-1-S150, 125-1-S200, 150-1-S200, 150-1-S230, 200-1-S200, 200-1-S230, 200-1-S260

Assembly steps:

- 7.1 Open the pack of the support system. Identify the items from table (page 5) and the drawing next page.
- 7.2 Assembly the parts among themselves using the set of bolts and nuts included in the pack. When assembling the tank supports to the profiles, pay attention to use the proper pair of holes to match the roof inclination, so that the tank would remain (as close as possible) vertical. At this stage do not fasten tight the bolts.
- 7.3 Fix the support system on the roof structure as shown on drawing. Make sure that this kind of fixing is suitable to withstand up to 97,2 Km/hr wind speed. If in doubt, consult your supplier, or your engineer for possible alternative way of fixing.
- 7.4 Fix collector on support as shown on drawing using the M6X20 bolts and washers (No. 22-23). Do not fasten tight yet
- 7.5 Position the tank on supports.. Fasten well with the 2 bolts M10X30 the tank on the support system. (The 2 bolts are already mounted on the tank and have to be temporarily removed before placing the tank on the support).
- 7.6 Now, fasten well the collector on support and then fasten well all the parts of the support system among themselves.
- 7.7 Connect the insulated copper pipes at closed loop system. The long pipe is for cold return to bottom of collector. The short pipe is for hot supply from top of collector. Make sure that you fasten well the “compression” fittings in order to tight the closed loop.
- 7.8 Connect the non-return pressure safety valve on the cold water inlet of tank making sure that the arrow is pointing towards the tank (upwards) and the escape outlet is facing sideways parallel to the tank.
- 7.9 Connect cold water supply using always a shut-off water valve. (Make sure the pipes are well insulated).
- 7.10 Connect hot water outlet piping to consumption points. It is strongly recommended to install a thermostatic mixing valve set at 55°C on the hot water piping anywhere before the consumption points. (Make sure the pipes are well insulated).
- 7.11 Fill the tank with cold water. Leave open one “tap” of hot water, so that air will be flushed out and the tank will be completely filled up.
- 7.12 Fill up the closed loop system with thermo-convention liquid from the top pipe (point 15). Make sure that no air-bubbles are coming out so filling is completed.
- 7.13 Screw the bronze cap with the copper ring on the filling point to seal the closed loop system. The closed loop is permanently sealed.
- 7.14 Check for leakages on open or closed loop system.
- 7.15 The (optional) electric heater should be connected by a fully licensed electrician following the national standards for electric installations.

Connections points on thermostat:

No 1 : Line L (220 volt)

No 4 : Neutral N

On metal flange: : Earth

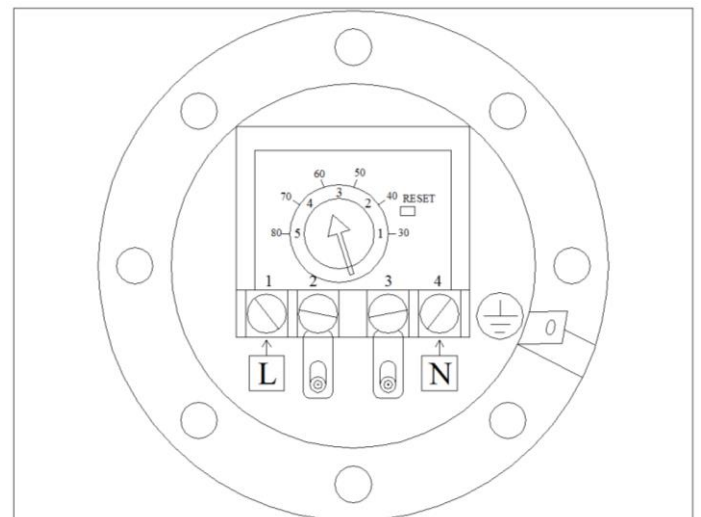

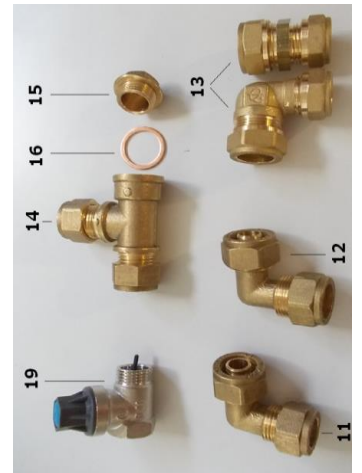
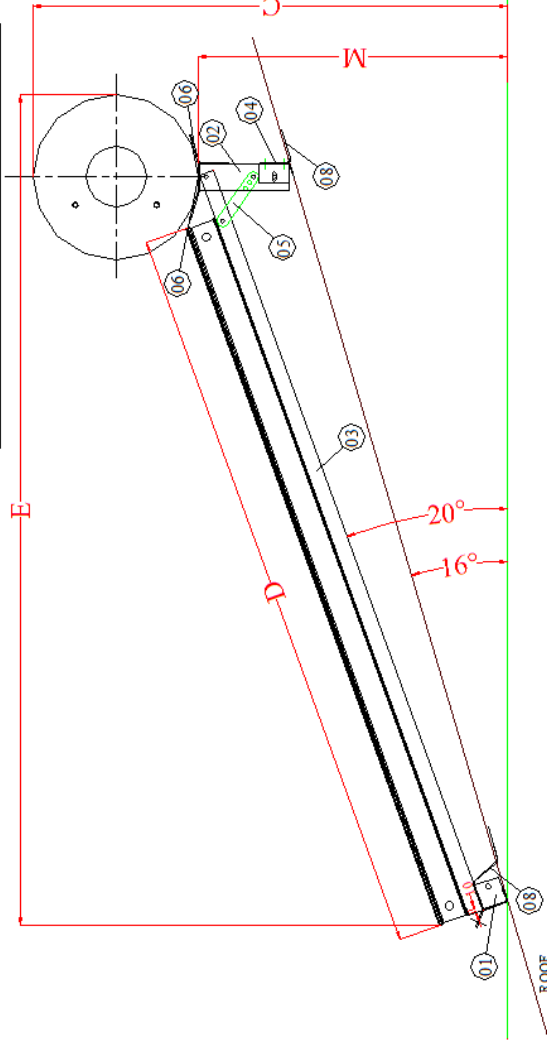
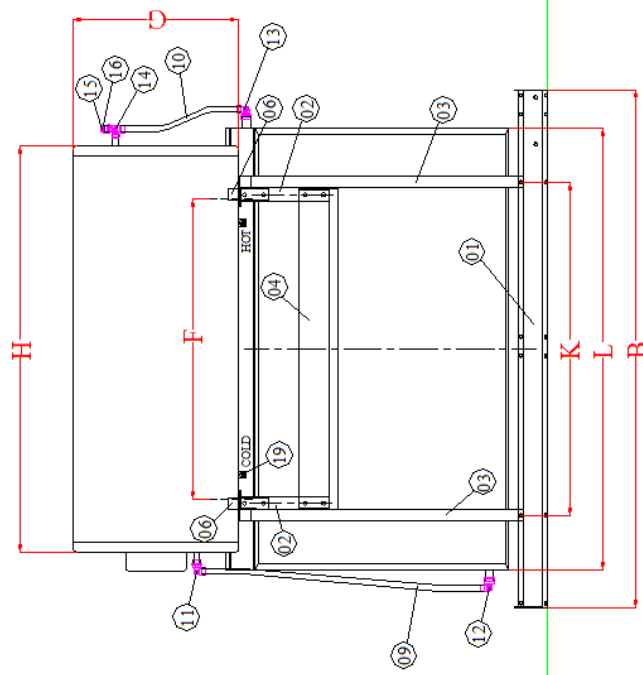
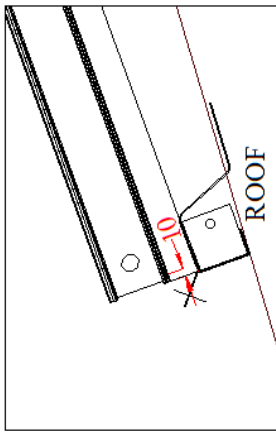
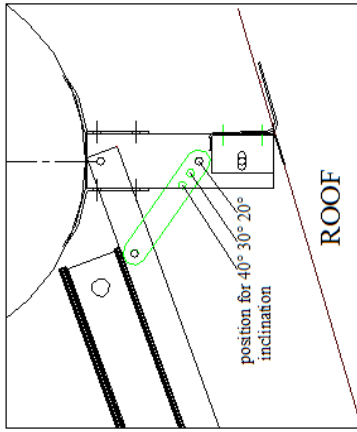

DIMENSION	ECO 125-1-150	ECO 125-1-200	ECO 150-1-200	ECO 150-1-230	ECO 200-1-200	ECO 200-1-230	ECO 200-1-260
B	1107mm	1377mm	1377mm	1377mm	1377mm	1377mm	1489mm
C	1118mm	1262mm	1322mm	1322mm	1352mm	1352mm	1411mm
D	1540mm	1960mm	1960mm	1960mm	1960mm	1960mm	2135mm
E	1814mm	2208mm	2238mm	2238mm	2253mm	2253mm	2418mm
F	800mm	800mm	800mm	800mm	800mm	800mm	800mm
G	440mm	440mm	500mm	500mm	530mm	530mm	530mm
H	1060mm	1125mm	1125mm	1125mm	1125mm	1145mm	1145mm
K	895mm	895mm	895mm	895mm	895mm	895mm	895mm
L	960mm	960mm	960mm	1165mm	960mm	1165mm	1238mm
M	678mm	822mm	822mm	822mm	822mm	822mm	881mm

8. Inclined roof - Tiles

Assembly instructions for systems with 2 collectors:

Models: 150-2-S150, 200-2-S200, 300-2-S200, 300-2-S230

Assembly steps:

- 8.1 Open the pack of the support system. Identify the items from table (page 5) and the drawing next page.
- 8.2 Assemble the parts among themselves using the set of bolts and nuts included in the pack. When assembling the tank supports to the profiles pay attention to use the proper pair of holes to match the roof inclination, so that the tank would remain (as close as possible) vertical. At this stage do not fasten tight the bolts.
- 8.3 Fix the support system on the roof structure as shown on drawing. Make sure that this kind of fixing is suitable to withstand up to 97,2 Km/hr wind speed. If in doubt, consult your supplier, or your engineer for possible alternative way of fixing.
- 8.4 Fix collectors on support as shown on drawing using the M6X20 bolts and washers (No. 22-23). Do not fasten tight yet.
- 8.5 Position the tank on supports. Two people for 200 ltr and four people for 300 ltr are needed to handle it from each end. Fasten well with the 2 bolts M10X30 the tank on the support system. (The 2 bolts are already mounted on the tank and have to be temporarily removed before placing the tank on the support).
- 8.6 Now, fasten well the collectors on support and then fasten well all the parts of the support system among themselves.
- 8.7 Connect the insulated copper (or plastic) pipe at closed loop system. The long pipe is for cold return to bottom of collector. The short pipe is for hot supply from top of collector. Make sure that you fasten well the “compression” fittings in order to tight the closed loop. Fix and fasten well the 2 compression end caps on the 2 remaining open ends of the collectors.
- 8.8 Connect the non-return pressure safety valve on the cold water inlet of tank making sure that the arrow is pointing towards the tank (upwards) and the escape outlet is facing sideways parallel to the tank, in order to prevent harm or burning during steam escape.
- 8.9 Connect cold water supply using always a shut-off water valve. (Make sure the pipes are well insulated).
- 8.10 Connect hot water outlet piping to consumption points. It is strongly recommended to install a thermostatic mixing valve set at 50-55°C on the hot water piping anywhere before the consumption points. (Make sure the pipes are well insulated).
- 8.11 Fill the tank with cold water. Leave open one “tap” of hot water, so that air will be flushed out and the tank will be completely filled up.
- 8.12 Fill up the closed loop system with thermo-convention liquid from the top pipe (point 15). Make sure that no air-bubbles are coming out so filling is completed.
- 8.13 Screw the bronze cap with the copper ring on the filling point to seal the closed loop system. The closed loop is permanently sealed.
- 8.14 Check for leakages on open or closed loop system.
- 8.15 The (optional) electric heater should be connected by a fully licensed electrician following the national standards for electric installations.

Connections points on thermostat:

No 1 : Line L (220 volt)
No 4 : Neutral N

On metal flange: : Earth

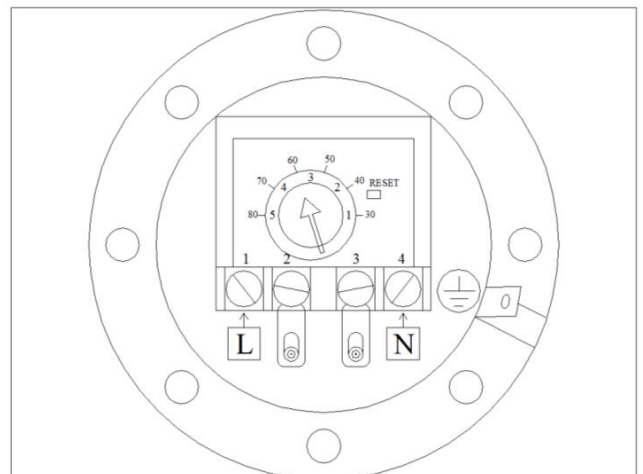

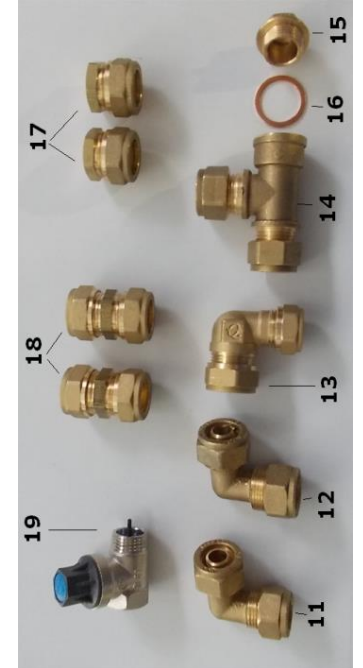
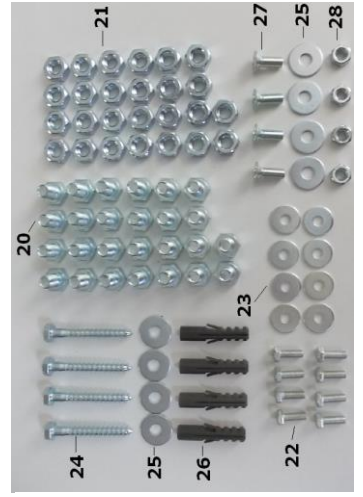
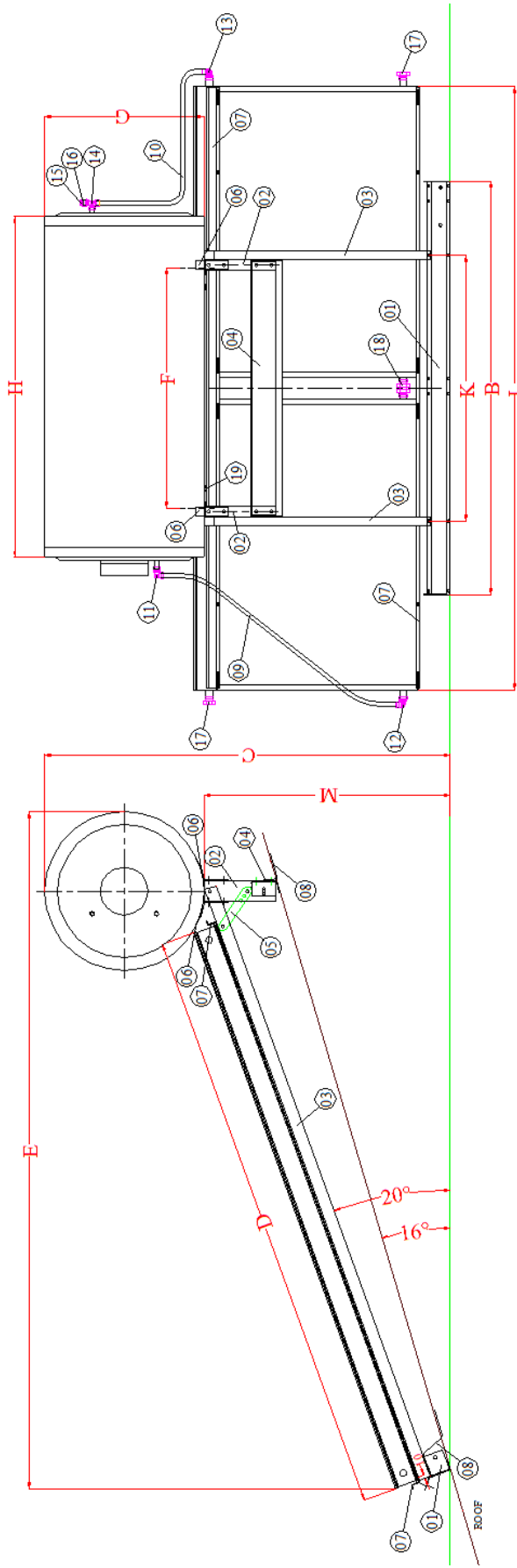
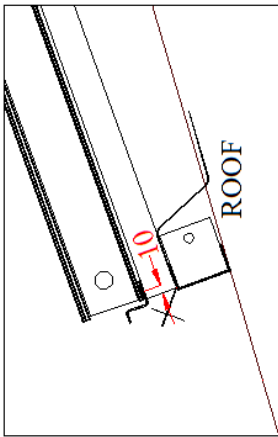
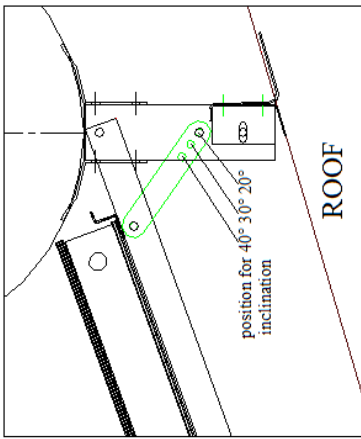

DIMENSION	ECO 150-2-150	ECO 200-2-200	ECO 300-2-200	ECO 300-2-230
B	1107mm	1377mm	1465mm	1465mm
C	1178mm	1352mm	1352mm	1352mm
D	1540mm	1960mm	1960mm	1960mm
E	1844mm	2254mm	2254mm	2254mm
F	800mm	800mm	1345mm	1345mm
G	500mm	530mm	530mm	530mm
H	1125mm	1145mm	1835mm	1835mm
K	895mm	895mm	1439mm	1439mm
L	2010mm	2010mm	2010mm	2420mm
M	678mm	822mm	822mm	822mm

9. Check list for installer

Before leaving from the installation, make sure that:

1. Cold and hot insulated pipes of closed loop system have a continuous ascending slope to the tank. Small partitions of the piping are allowed to be horizontal, but never descending to the tank. This will allow the air bubbles to move towards the tank, in the internal expansion tank and would not obstruct recirculation.
2. The closed loop system is operating properly. This can be identified, after one hour of sun shine by touching the hand on the hot inlet of tank (from top of collector) and at the same time on the cold outlet (to bottom of collector). There must be a significant temperature difference which means that the natural recirculation is functioning.
3. There is no leakage at the closed loop or open loop circuit.
4. All bolts and nuts of the support system have been tightened very well and that the fixing on roof is made properly to withstand strong winds.
5. Cold supply and hot return piping are properly installed and secured so that the wind will not move them. They should be properly insulated with a certified insulation material of minimum thickness 9mm and maximum thermal conductivity of 0.037 W/m²K, and well finished in order to be resistant against rain and moisture.
6. The (optional) electric heater is functioning properly and the thermostat is set maximum at 55°C to 60°C
7. You have explained to the users the operation of their solar system and the capabilities of the installed model.
8. You have signed and delivered to the owner the guarantee.

10. Operation instructions

- Your solar heater is a two circuit system. The primary circuit recirculates from collectors to a heat exchanger inside the tank, thus transferring solar energy to the domestic water.
- Primary system contains antifreeze glycol for frost protection of collectors.
- Temperature of hot water depends on solar irradiation of the day, season of year, ambient temperature, cold water inlet temperature, time of day using hot water, quantity used.
- Best timing for use: 12.00 noon – 3.00p.m. and 5.00 p.m. to 8.00 p.m.
- If you need hot water early in the morning, avoid excess consumption previous evening.
- For a shower, 30-60 ltr hot water is needed.
- For filling bathtub, 120-150 ltr hot water is needed.
- If your solar system is equipped with the optional electric heater, switch on only when needed for emergency situations and for 1 to 2 hours. **NEVER** leave electric heater permanently ON. The thermostat is adjusted to 55°C-60°C.
- In the event of any failure condition a specialist should be called in.

11. Maintenance instructions

For long-life of your solar heater follow below given instructions:

- At least once a year check for excessive dust on collectors. Wash with cold water at early morning before 10.00 a.m. when the glass is cold.
- Every two years replace magnesium protection anode. (contact your installer)
- Every 4 years check and paint if necessary with grey color primer the support frame.
- At extremely cold winter nights (below 0°C) leave a hot water tap inside house slightly open to prevent pipe freezing.
- If solar heater doesn't warm up with sunshine, check for leakage in primary circuit. Restore the leakage, add antifreeze. Check also for leakages in domestic hot water piping network. Restore if needed.
- When by any reason glass is broken, replace the soonest possible.
- When electric heater is not functioning check for burned fuse or for "safety" contact of thermostat activation. Press inside the button with the mark ▼ to restore and adjust thermostat lower.

12. Decommissioning of the system

- If your product has electric backup, please turn off its power supply before dismantling the solar water heater.
- Drain down the hot water cylinder
- Cut the inlet pipe to the panel first and then the outlet pipe from the top of the panel to the top of the cylinder
- Remove the tank from supports. Two people are needed to handle it from each end.
- Unfasten the collectors of support and then unfasten all the parts of the support system among themselves.
- Release collectors from support and disassemble the parts among themselves, remove the support system from the roof.

Recommendations:

- Recycle or reuse its component materials if possible.
- Protect your hands and eyes
- Avoid decommissioning during sunlight
 - If you need further technical support contact your local distributor

Published: June 2017, version 6

SOLE S.A.

SOLAR DOMESTIC APPLIANCES MANUFACTURER

Lefktron & Laikon Agonon, 136 71 Acharnai – Athens – Greece

Tel.: (+30210) 2389500 • Fax: (30210) 2389502

Email: export@sole.gr • www.eurostar-solar.com