



# INSTALLATION & USERS MANUAL



**DOMESTIC SOLAR WATER HEATER**



**THERMOSIPHON SYSTEM**

**CLOSED CIRCUIT**

**MODELS EUROSTAR ECO LOW HEIGHT :**

150-1-S200, 150-1-S230, 200-1-S230, 300-2-S200, 300-2-S230

## INDEX

1. Observance of the instructions and standards.....	2
2. Description of solar system and components .....	2
2.1 General Description .....	2
2.2. Collector .....	2
2.3. Accumulation tank (cylinder) .....	3
(*) Required quantities for: <i>flat roof / inclined roof (tiles)</i> .....	5
<i>(All the other quantities are the same for flat roof or inclined roof installation)</i> .....	5
2.5. Thermo convention liquid .....	6
3. Warnings.....	6
4. Recommendations.....	7
5. Flat roof .....	8
Assembly instructions for systems with 1 collector: .....	8
Models: 150-1-S200, 150-1-S230, 200-1-S230 .....	8
6. Flat roof .....	9
Assembly instructions for systems with 2 collectors: .....	10
Models: 300-2-S200, 300-2-S230 .....	10
7. Check list for installer .....	12
8. Operation instructions.....	13
9. Maintenance instructions.....	13
10.Decommissioning of the system .....	13
11. 3D Sketches of 1 collector and 2 collectors ECO Eurostar Solar Systems (Low) .....	15

## **1. Observance of the instructions and standards.**

**1.1. It is very important to follow these installation, operating and maintenance instructions**, in order to avoid danger of death, injury, property damages, and to have your device functioning properly in the long run. The company that manufactured and/or supplied this solar system has no liability for the installer and/or the user in case these instructions have not been followed carefully.

**1.2. Whether further information or clarifications are needed, please contact the supplier of the product.**

**1.3. These solar systems have been manufactured and tested under the European standards:**

ISO 9806:2013: Energy – Solar Thermal Collectors – Test methods

EN 12975-1: Thermal solar systems and components – Solar collectors -part 1: General requirements.

EN 12975-2: Thermal solar systems and components – Solar collectors – part 2 : Test methods.

EN 12976-1: Thermal solar systems and components – Factory made systems - part 1: General requirements.

EN 12976-2: Thermal solar systems and components – Factory made systems – part 2: Test methods.

**1.4. These systems are in conformity with the applicable requirements of the following documents:**

<i>Ref. No.</i>	<i>Title</i>
EN 60335-1:2012 +A11:2014 (IEC 60335-1:2010)	Household and similar electrical appliances — Safety — Part 1: General requirement
EN 60335-2-21:2003 +A2:2008 (IEC 60335-2-21:2002 +A2:2008)	Household and similar electrical appliances — Safety — Part 2-21: Particular requirements for storage water heaters
EN 60529:1991 +A1:2000 +A2:2013 (IEC 60529:1989 +A1:1999 +A2:2013)	Degrees of protection provided by enclosures (IP code)
ENV 61024-1:1995 (IEC 61024-1:1990)	Protection of structures against lightning Part 1: General principles

The manufacturer declares that the equipment named in this document have been designed to comply with the relevant sections of the above referenced specifications.

## **2. Description of solar system and components**

### **2.1 General Description**

This solar system is a closed loop thermosiphon unit which delivers hot water for domestic use. It consists from the collector, the accumulation tank, the support system, the hydraulic accessories and the thermo-convention liquid.

Four nominal sizes of accumulation tanks are combined with four different sizes of collectors as the table below:

MODEL	TANK NOMINAL SIZES			COLLECTOR NOMINAL SIZES		
	150 ltrs	200 ltrs	300 ltrs	2,00m <sup>2</sup>	2,30m <sup>2</sup>	2,60m <sup>2</sup>
<b>150-1-200</b>	1			1		
<b>150-1-230</b>	1				1	
<b>200-1-230</b>		1			1	
<b>300-2-200</b>			1	2		
<b>300-2-230</b>			1		2	

### **2.2. Collector**

The collectors are manufactured in 3 sizes with nominal area of -2, 00m<sup>2</sup>-2.30m<sup>2</sup> -2,60m<sup>2</sup>. The absorbers of the collectors are made by copper tubes and the fins area by selective aluminum fins. The fins are welded to the tubes by laser welding. The frame of the collector is made by extruded aluminum epoxy oven painted to resist ambient conditions.

The glass cover is a “prismatic securit” glass of 3.2mm thickness for maximum penetration of solar irradiation. At the back and sides of the absorber there is sufficient insulation of rock wool and glass wool to minimize heat losses and to resist stagnation temperatures.

Technical data of collector as the table below:

	Nominal size (m <sup>2</sup> )		
	2,00	2,30	2,60
<b>Length (mm)</b>	1960	1960	2135
<b>Width (mm)</b>	960	1165	1238
<b>Depth (mm)</b>	81	81	81
<b>Weight (kg)</b>	32,0	38,8	44

Stagnation temperature: 164°C

Test pressure: 22.5 bar

Operating pressure: 15bar

### 2.3. Accumulation tank (cylinder)

The solar accumulation tank is an indirect (double circuit) hot water horizontal cylinder. The inner surface is enameled at 850°C to guarantee potable sanitary water for long life. Additionally it is protected against rusting with a large magnesium anode.

The ecologic polyurethane foam insulation guarantees minimum thermal losses even at very low ambient temperatures. The external cover of the tank can resist any extreme weather conditions for life. The internal heat exchanger with large surface guarantees the energy transfer to the domestic hot water.

The hot water exits from the hottest zone (level) of the tank. At the same time equal quantity of cold water enters the tank at the coldest zone (level). The solar tank can be optionally (accessory) equipped with immersion electric heater (electric element) for use only for emergency situations. The immersion electric heater is available in 2 kW or 3kW or 4 kW at 230 Volt. It is equipped with control thermostat set at 60° C and safety thermostat (thermal cut out) manually reset.

The safety valve only opens to discharge when the system pressure exceeds 10bar in the form of water.

Technical Data of tanks as table below:

	Nominal size		
	150	200	300
<b>Length (mm)</b>	1185	1215	1915
<b>Diameter (mm)</b>	500	530	530
<b>Weight (kg)</b>	46,7	50,8	83
<b>Capacity (ltr) (Incl. h.exchanger)</b>	142	170	276
<b>Test pressure (bar)</b>	22.5	22.5	22.5
<b>Operating pressure (bar)</b>	15	15	15
<b>Max temperature (°C)</b>	90 °C	90 °C	90 °C
<b>Cold &amp; hot water connectors (male)</b>	½"	½"	½"

## 2.4. Support System

The support system is made from galvanized pressed steel. It is designed for flat installation at 33°. Also it can withstand wind velocity up to 97,2 km/hr. and weight of snow up to 64cm height. In order to assembly the support system the following tools are needed.

- Spanner 10mm 1 X 
- Spanner 13mm 1 X 
- 2 Spanners 17mm 2 X 
- Screwdriver 1 X 
- Drill Ø10 (for fastening the system on the roof) 

The material list for each set of support system is:

	Part	MODEL					
		150-1-200	150-1-230	200-1-230		300-2-200	300-2-230
<b>SET OF SUPPORT FRAME PARTS</b>							
01	A11-40 :profile in Π section 878mm	2	2	2		2	2
02	D14 :profile in Π section 1990mm	2	2	2		2	2
03	Tank support 280x195mm	2	2	2		2	2
04	H :bracket in Π section 850mm	1	1	1		-	-
	H11 :bracket Π section1400mm	-	-	-		1	1
05	C :profile in Π section 550mm	2	2	2		2	2
06	X1 :bracket 1250mm	2	2	2		2	2
07	E1 :angle Z shape 2000mm	-	-	-		2	-
	E2 :angle Z shape 2310mm	-	-	-		-	2
09	Insulated long pipe Ø15mm (for close loop cold water)	2.08m	2.05m	2.05m		2.07m	2.06m
10	Insulated short pipe Ø 15mm (for close loop hot water)	0.50m	0.41m	0.41m		0.40m	0.54m
<b>SET OF FITTINGS</b>							
11	Compression Elbow Male ½" x Ø15	2	2	2		2	2
	Non return valve (for closed loop)	1	1	1		1	1
12	Compression Elbow Ø18 x Ø15	1	1	1		1	1
13	Compression Elbow Ø18 x Ø15	-	1	1		1	1
	Compression Union Ø18 x Ø15	1	-	-		-	-
14	Tee connector female Ø15 x ½" x Ø15	1	1	1		1	1
	Compression Elbow Female ½" x Ø15	1	1	1		1	-
15	End Cap male ½"	1	1	1		1	1
16	Copper Ring ½"	1	1	1		1	1
17	Compression End Cap Ø18	-	-	-		2	2
18	Compression Connector Ø18 x Ø18	-	-	-		2	2
19	Pressure Safety Valve 8 bar (for open loop)	1	1	1		1	1
<b>SET OF BOLTS AND NUTS</b>							
20	Bolt M10x16 (DIN 933/8.8)	18	18	18		18	18
21	Nut M10 (DIN 934/8)	18	18	18		18	18
22	Bolt M6x20 (DIN 933/8.8)	4	4	4		8	8
23	Washer Ø6 (DIN 9021)	4	4	4		8	8
24	Anchored Bolt M8x60 (DIN 571)	4	4	4		4	4
25	Washer Ø8 (DIN 9021)	4	4	4		4	4
26	Plastic Rawlplugs D10	4	4	4		4	4
27	Cross Recess Counter Sunk Head Bolt M8x20 (DIN 7969)	-	-	-		4	4
28	Nut M8 (DIN 934/8)	-	-	-		4	4

## 2.5. Thermo convention liquid

The thermal energy collected from the solar irradiation by the collector is transferred to the heat – exchanger of the tank by the thermo convention liquid, which is naturally re circulated by the thermosiphonic principle in the closed loop system. The heat exchanger is heating the domestic consumption water. The solution contains inhibitors for antirust protection and propylenoglycol for antifreeze protection up to -15°C. If lower temperature protection is needed please consult your supplier. The solution is a non toxic, non-flammable chemical liquid; however normal protection measures should be taken during handling. Keep it away from children.

Eyes protection: Protective glasses must be used.

Skin protection: PVC or rubber gloves must be used.

- In case of contact with eyes, wash eyes with plenty of water for 15 minutes (with open eyelids)
- In case of contact with skin simply wash with water and soap.

### **Physical Properties:**

Phase: liquid

Color: Light red

Odor: nearly odorless

Specific gravity at 20°C : 1,03g/cm<sup>3</sup>

Freezing point: -15°C

Boiling point: 106°C

Packing: Containers of 2ltr. & 4ltr. ready for usage.

## 2.6. Packaging, Transport and Storage

The solar collectors and the solar tanks are supplied individually packaged, the collectors in carton boxes and the tanks with stretch film and expanding polystyrene. The collector model is indicated on the outside of each box and the tank model is indicated outside of each package. Depending on the number of units ordered, collectors can be supplied palletised in groups of up to 12 units. Collectors should always be during transport and storage placed in horizontal position with the glass facing on top, otherwise there is danger of water entering in the collectors from the ventilation holes at the back of the collector. They should not be stored or transported in piles of more than 12 units. The tanks can be supplied palletised in groups of up to 10 units. Alternatively, under request, the whole system can be palletised in individual pallets. The tanks should be always in vertical position during transportation and should not be stored or transported in piles of more than 2 units. It is recommended to use special safety belts during transportation in order to avoid movements and/or falling.

## 3. Warnings

Before starting installation, the installer should read and observe carefully the following warnings in order to avoid danger of death, injury or property damages.

3.1. You may elevate on roof the parts of the solar system, ONLY when an internal staircase of enough width, exists in the building reaching the roof. Otherwise you must use a proper CRANE to elevate the parts. It is not allowed to stand at the edge of any roof (flat or inclined) and pull by ropes any part. DANGER OF DEATH.

3.2 The collectors have a large surface exposed to wind. NEVER install a system with strong winds. Choose a calm day. DANGER OF DEATH or heavy injury.

3.3. If the installation will be on an inclined roof (tiles), there is danger of slipping. Use always SAFETY BELTS (securely fastened) from a higher position of roof. DANGER OF DEATH.

3.4. After completion of the installation make sure that all bolts and nuts are fastened well and the whole system is securely fastened to the roof. The support system can withstand air velocities up to 97,2 km/hr.

Make sure that the fastening on roof can withstand as well at least same air velocity. DANGER OF DEATH.

3.5. Frequently some parts of the support systems have sharp edges. Use always gloves when you are handling the support system, in order to avoid danger of injuring the hands. DANGER OF INJURY.

3.6. The collectors when exposed to solar irradiation during installation get very hot; above 120° C in 2-3 minutes. There is danger of burning the hands when touching the copper piping outlets. You must leave the carton package cover ON the glass until completion of the installation, or you must use thermo resistance gloves. DANGER OF INJURY.

3.7. If you are using hands to position the tank on the support system at least 2 people are needed for systems 120-150.

It is preferred to use a crane. In this case make sure that the pulling belts are on each side between the piping outlets of the boiler so that it cannot slip.

3.8. In cases where the solar system is large and the hot water consumption is low, the hot water in the solar tank may reach temperatures up to 90°C. In this case there is danger of burns for the user, especially for children.

It is strongly recommended to install a thermostatic mixing valve set at 55°C anywhere at the hot supply piping and before the hot outlets of the building (before taps, showers, e.t.c.)

3.9. If the solar system is equipped with the (optional) electric immersion heater, the electrical connection should be done by a fully licensed electrician following the national rules for electric installation.

The immersion heater is single phase 230 Volt of 2kW or 3 kW or 4 kW power.

There is an "earth point" on the flange of the heater which must be connected to the central "earth" of the building. In any case the support of the solar system must be "earthed" with copper wire of 16 mm<sup>2</sup> to the earthing grid of the building. This will also serve as lightning protection.

3.10 In a solar system equipped with the optional electric heater, after completion of electrical and plumbing installation test the operation of the electric heater and thermostat, ONLY AFTER FILLING the tank with city water. Otherwise the electric heater will be fused out. (destroyed)

3.11 Make sure that before filling the tank with city water the pressure safety non-return valve has been installed on the cold water inlet with the arrow pointing to the tank. This valve will open and release the pressure when by overheating or other reason it has exceeded 10 bar.

3.12. When handling the thermo-convention liquid make sure that you wear protective glasses for the eyes and gloves for the skin.

3.13. When temporarily leave the collectors on the roof during installation ALWAYS position them with glass facing the sky. Otherwise there is danger that water from rain may enter the collector from the back side through the ventilation holes. If this happens the insulation will be wet and the glass will have humidity on inside surface. Drying will take a very long time.

#### **4. Recommendations**

4.1 The cold water piping should withstand pressure of 10 bar. The hot water piping should withstand temperature of 95° C at pressure 10 bar.

4.2. The cold and hot water piping should be well insulated to eliminate heat losses and prevent as possible freezing. The insulation material should withstand weather conditions like rains, snow and solar irradiation.

4.3. On the hot water supply piping, install a reliable thermostatic mixing valve set at 55°C to prevent higher temperature hot water to reach the consumption points.

4.4. The system may only be installed in locations with lower values of  $s_k$  (snow load) 0.64m and  $v_m$  (average wind velocity) 97.2km/h

## 5. Flat roof

### Assembly instructions for systems with 1 collector:

Models: 150-1-S200, 150-1-S230, 200-1-S230

#### Assembly steps:

- 5.1. Open the pack of the support system. Identify the items from table (page 5) and the drawing next page.
- 5.2. Assemble the parts between themselves using the set of bolts and nuts included in the pack. At this stage do not fasten tight the bolts.
- 5.3. Fix collector on support as shown on drawing using the M6X20mm bolts and washers (No. 22-23). Do not fasten tight yet.
- 5.4. Position the tank on supports. Two people are needed to handle it from each end. Fasten well with the 2 bolts M10X30 the tank on the support system. (The 2 bolts are already mounted on the tank and have to be temporarily removed before placing the tank on the support).
- 5.5. Now, fasten well the collector on support and then fasten well all the parts of the support system among themselves.
- 5.6. Drill the "floor" with 10mm drill at the 4 fixing points, insert the raw-plugs provided, and fasten well the whole support system to the "floor". Make sure that the material of "floor" is suitable (concrete) for this kind of fixing, in order to withstand up to 97,2 Km/hr wind speed. If in doubt, consult your supplier, or your engineer for possible alternative way of fixing.
- 5.7. Connect the insulated copper (or plastic) pipe at closed loop system. The long pipe is for cold return to bottom of collector. The short pipe is for hot supply from top of collector. Make sure that you fasten well the "compression" fittings in order to tight the closed loop.
- 5.8. Connect the non-return pressure safety valve on the cold water inlet of tank, making sure that the arrow is pointing towards the tank (upwards) and the escape outlet is facing sideways parallel to the tank.
- 5.9. Connect cold water supply using always a shut-off water valve. (Make sure the pipes are well insulated)
- 5.10. Connect hot water outlet piping to consumption points. It is strongly recommended to install a thermostatic mixing valve set at 50-55°C on the hot water piping anywhere before the consumption points. (Make sure the pipes are well insulated).
- 5.11. Fill the tank with cold water. Leave open one "tap" of hot water, so that air will be flushed out and the tank will be completely filled up.
- 5.12. Fill up the closed loop system with thermo-convention liquid from the top pipe (point 15). Make sure that no air-bubbles are coming out so filling is completed.
- 5.13. Screw the bronze cap with the copper ring on the filling point to seal the closed loop system. The closed loop is permanently sealed.
- 5.14. Check for leakages on open or closed loop system.
- 5.15. The (optional) electric heater should be connected by a fully licensed electrician following the national standards for electric installations.

Connections points on thermostat:

No 1 : Line L (220 volt)  
No 4 : Neutral N

On metal flange:  : Earth

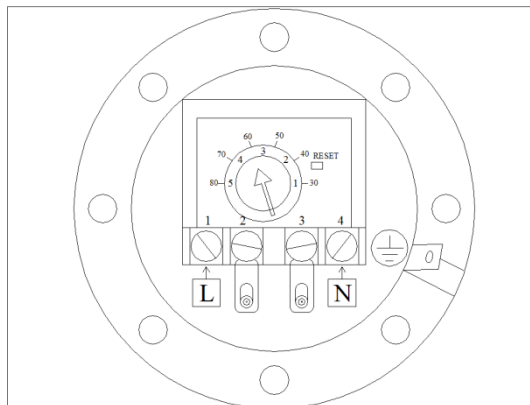

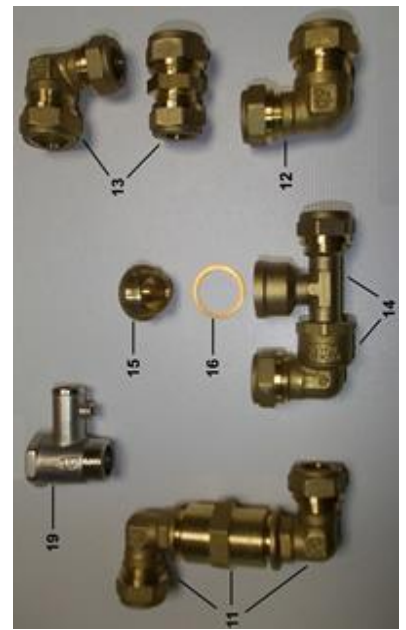
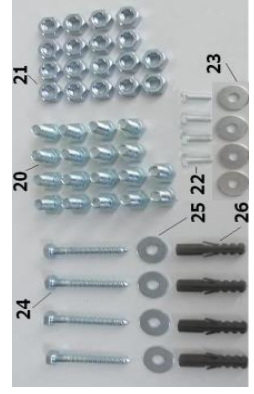
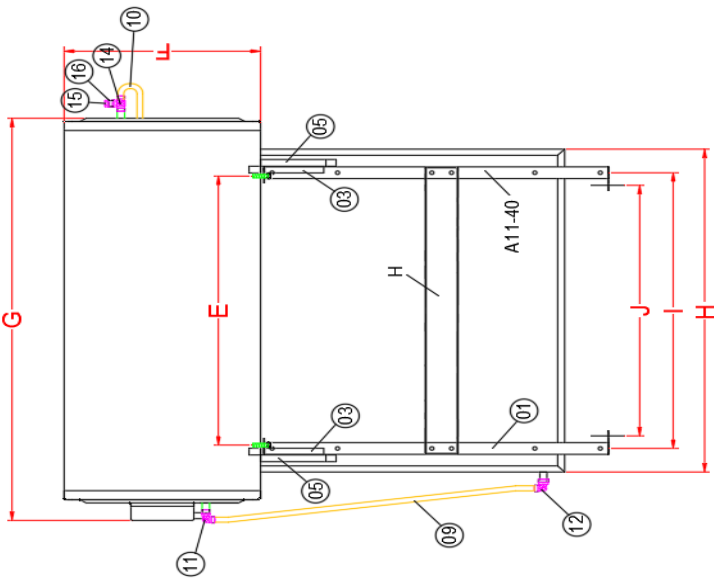
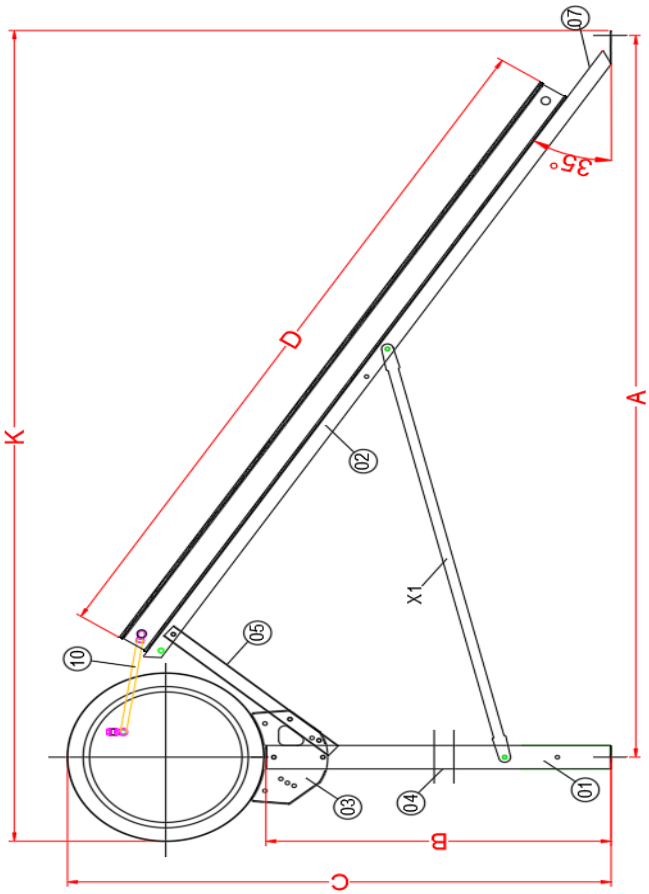

DIMENSION	ECO 150-1-200	ECO 150-1-230	ECO 200-1-230
A	2025mm	2025mm	2025mm
B	878mm	878mm	878mm
C	1383mm	1383mm	1413mm
D	1960mm	1960mm	1960mm
E	800mm	800mm	800mm
F	500mm	500mm	530mm
G	1195mm	1195mm	1215mm
H	960mm	1165mm	1165mm
I	820mm	820mm	820mm
J	745mm	745mm	745mm
K	2411mm	2411mm	2426mm

## 6. Flat roof

### Assembly instructions for systems with 2 collectors:

Models: 300-2-S200, 300-2-S230

#### Assembly steps:

- 6.1. Open the pack of the support system. Identify the items from table (page 5) and the drawing next page.
- 6.2. Assembly the parts between themselves using the set of bolts and nuts included in the pack. At this stage do not fasten tight the bolts.
- 6.3. Fix collectors on support as shown on drawing using M6X20 bolts and washers (No 22 &23 at table) Do not fasten tight yet.
- 6.4. Position the tank on supports. Two people for 200 ltr and four people for 300 ltr are needed to handle it from each end. Fasten well with the 2 bolts M10X30 the tank on the support system. (The 2 bolts are already mounted on the tank and have to be temporarily removed before placing the tank on the support).
- 6.5. Now, fasten well the collectors on support and then fasten well all the parts of the support system among themselves.
- 6.6. Drill the "floor" with 10mm drill at the 4 fixing points, insert the raw-plugs provided, and fasten well the whole support system to the "floor". Make sure that the material of "floor" is suitable (concrete) for this kind of fixing, in order to withstand up to 97,2 Km/hr wind speed. If in doubt, consult your supplier, or your engineer for possible alternative way of fixing.
- 6.7. Connect the insulated copper (or plastic) pipe at closed loop system. The long pipe is for cold return to bottom of collector. The short pipe is for hot supply from top of collector. Make sure that you fasten well the "compression" fittings in order to tight the closed loop. Fix and fasten well the 2 compression end caps on the 2 remaining open ends of the collectors.
- 6.8. Connect the non-return pressure safety valve on the cold water inlet of boiler making sure that the arrow is pointing towards the tank (upwards) and the escape outlet is facing sideways parallel to the tank, in order to prevent harm or burning during steam escape.
- 6.9. Connect cold water supply using always a shut-off water valve. (Make sure the pipes are well insulated).
- 6.10. Connect hot water outlet piping to consumption points. It is strongly recommended to install a thermostatic mixing valve set at 50-55°C on the hot water piping anywhere before the consumption points. (Make sure the pipes are well insulated).
- 6.11. Fill the tank with cold water. Leave open one "tap" of hot water, so that air will be flushed out and the tank will be completely filled up.
- 6.12. Fill up the closed loop system with thermo-convention liquid from the top pipe (point 15). Make sure that no air-bubbles are coming out so filling is completed.
- 6.13. Screw the bronze cap with the copper ring on the filling point to seal the closed loop system. The closed loop is permanently sealed.
- 6.14. Check for leakages on open or closed loop system.
- 6.15. The (optional) electric heater should be connected by a fully licensed electrician following the national standards for electric installations.

Connections points on thermostat:

No 1 : Line L (220 volt)

No 4 : Neutral N

On metal flange:  ..: Earth

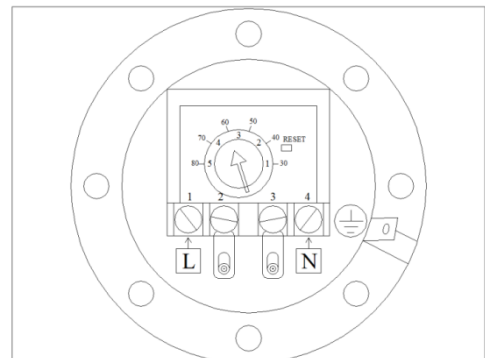

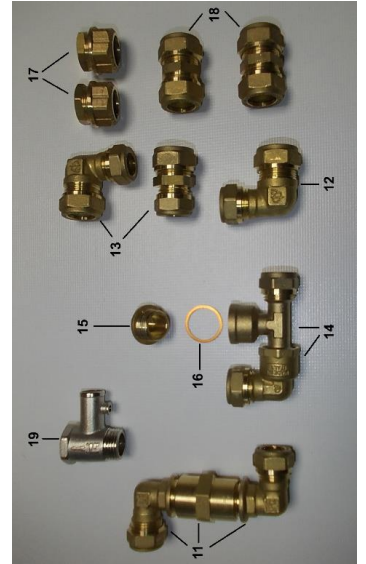
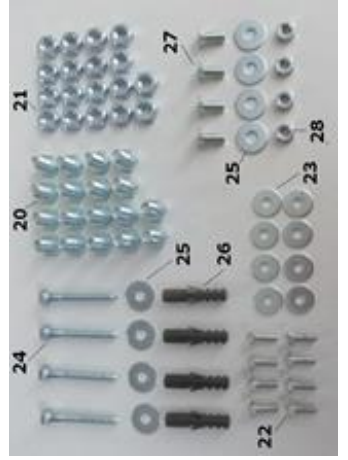
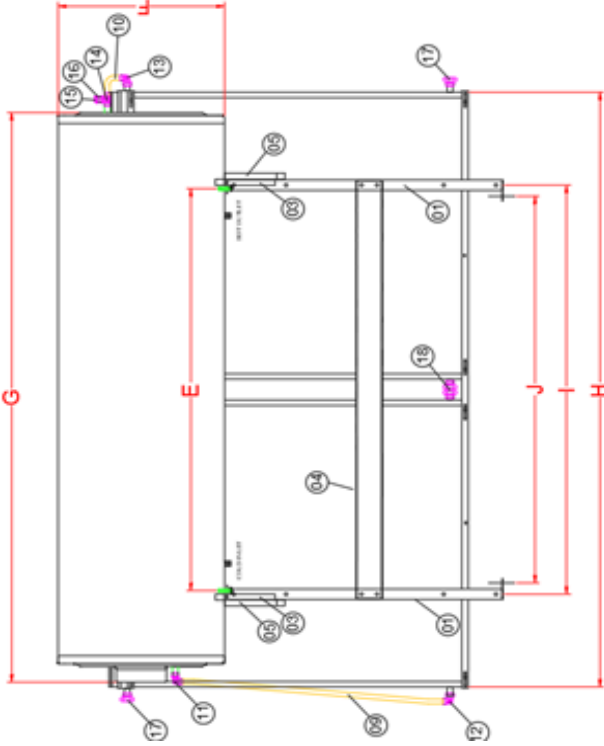
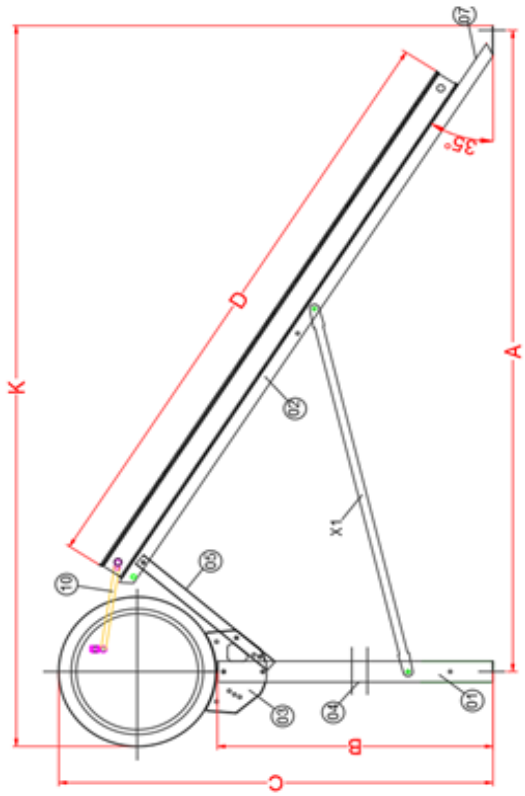

DIMENSION	ECO 300-2-200	ECO 300-2-230
A	2025mm	2025mm
B	878mm	878mm
C	1413mm	1413mm
D	1960mm	1960mm
E	1345mm	1345mm
F	530mm	530mm
G	1905mm	1905mm
H	1980mm	2390mm
I	1370mm	1370mm
J	1295mm	1295mm
K	2426mm	2426mm

## 7. Check list for installer

Before leaving from the installation, make sure that:

1. Cold and hot insulated pipes of closed loop system have a continuous ascending slope to the tank. Small partitions of the piping are allowed to be horizontal, but never descending to the tank. This will allow the air bubbles to move towards the tank, in the internal expansion tank and would not obstruct recirculation.
2. The closed loop system is operating properly. This can be identified, after one hour of sun shine by touching the hand on the hot inlet of tank (from top of collector) and at the same time on the cold outlet (to bottom of collector). There must be a significant temperature difference which means that the natural recirculation is functioning.
3. There is no leakage at the closed loop or open loop circuit.
4. All bolts and nuts of the support system have been tightened very well and that the fixing on roof is made properly to withstand strong winds.
5. Cold supply and hot return piping are properly installed and secured so that the wind will not move them. They should be properly insulated with a certified insulation material of minimum thickness 9mm and maximum thermal conductivity of  $0.037 \text{ W/m}^\circ\text{K}$ , and well finished in order to be resistant against rain and moisture.
6. The (optional) electric heater is functioning properly and the thermostat is set maximum at  $55^\circ\text{C}$  to  $60^\circ\text{C}$
7. You have explained to the users the operation of their solar system and the capabilities of the installed model.
8. You have signed and delivered to the owner the guarantee.

## **8. Operation instructions**

- Your solar heater is a two circuit system. The primary circuit recirculates from collectors to a heat exchanger inside the tank, thus transferring solar energy to the domestic water.
- Primary system contains antifreeze glycol for frost protection of collectors.
- Temperature of hot water depends on solar irradiation of the day, season of year, ambient temperature, cold water inlet temperature, time of day using hot water, quantity used.
- Best timing for use: 12.00 noon – 3.00p.m. and 5.00 p.m. to 8.00 p.m.
- If you need hot water early in the morning, avoid excess consumption previous evening.
- For a shower, 30-60 ltr hot water is needed.
- For filling bathtub, 120-150 ltr hot water is needed.
- If your solar system is equipped with the optional electric heater, switch on only when needed for emergency situations and for 1 to 2 hours. **NEVER** leave electric heater permanently ON. The thermostat is adjusted to 55°C-60°C.
- In the event of any failure condition a specialist should be called in.

## **9. Maintenance instructions**

For long-life of your solar heater follow below given instructions:

- At least once a year check for excessive dust on collectors. Wash with cold water at early morning before 10.00 a.m. when the glass is cold.
- Every two years replace magnesium protection anode. (contact your installer)
- Every 4 years check and paint if necessary with grey color primer the support frame.
- At extremely cold winter nights (below 0°C) leave a hot water tap inside house slightly open to prevent pipe freezing.
- If solar heater doesn't warm up with sunshine, check for leakage in primary circuit. Restore the leakage, add antifreeze. Check also for leakages in domestic hot water piping network. Restore if needed.
- When by any reason glass is broken, replace the soonest possible.
- When electric heater is not functioning check for burned fuse or for "safety" contact of thermostat activation. Press inside the button with the mark ▼ to restore and adjust thermostat lower.

## **10. Decommissioning of the system**

- If your product has electric backup, please turn off its power supply before dismantling the solar water heater.
- Drain down the hot water cylinder
- Cut the inlet pipe to the panel first and then the outlet pipe from the top of the panel to the top of the cylinder
- Remove the tank from supports. Two people are needed to handle it from each end.
- Unfasten the collectors of support and **then unfasten** all the parts of the support system among themselves.
- Release collectors from support and disassemble the parts among themselves, remove the support system from the roof.

Recommendations:

- Recycle or reuse its component materials if possible.
- Protect your hands and eyes
- Avoid decommissioning during sunlight
- If you need further technical support contact your local distributor

# ATTENTION!



**11. 3D Sketches of 1 collector and 2 collectors ECO Eurostar Solar Systems (Low)**

**A) 1- Collector System (150-1-S230) Parts**

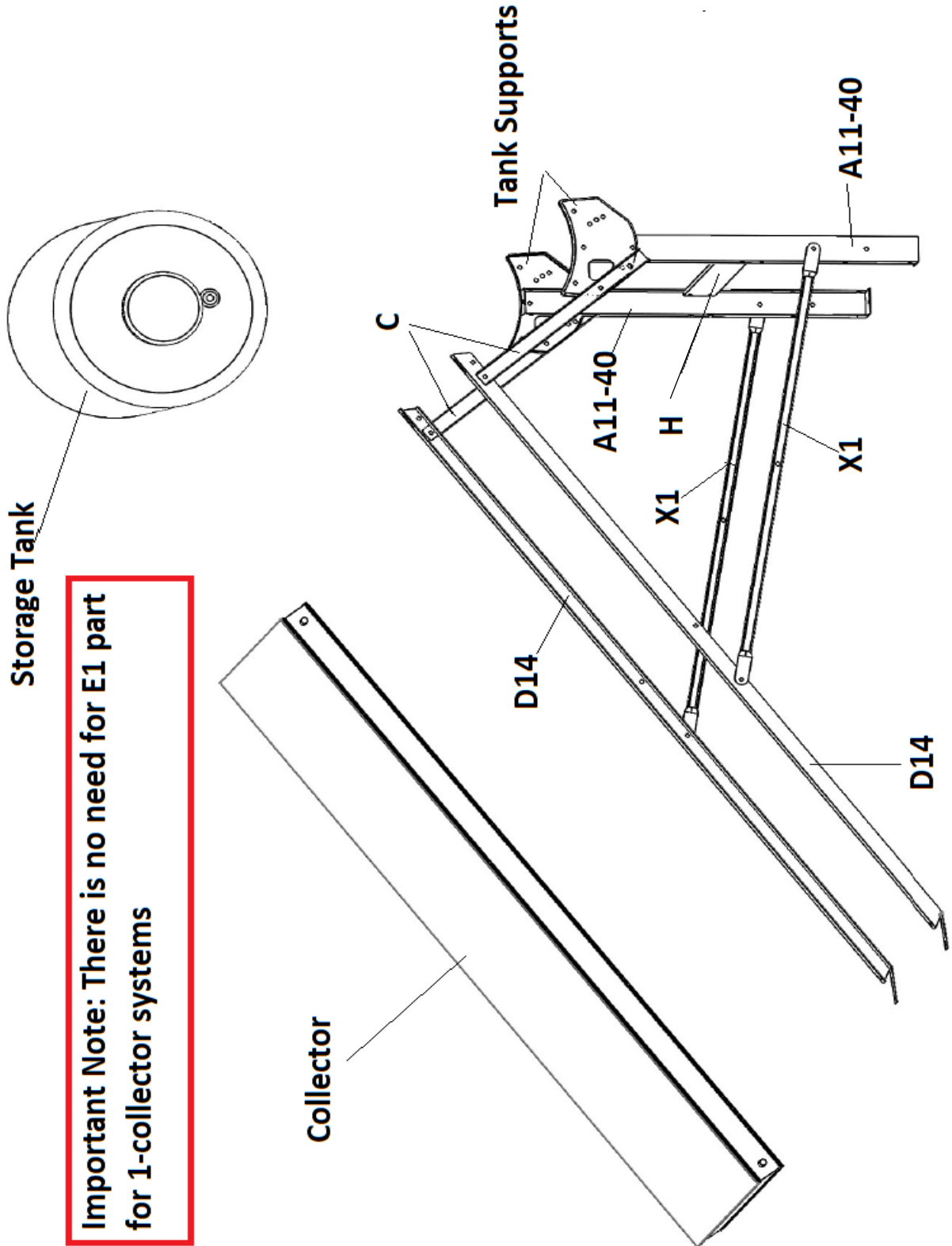

**Important Note: There is no need for E1 part for 1-collector systems**

B) 1- Collector System (150-1-S230) Piping

Solar Circuit Upper Pipe (Glycol)

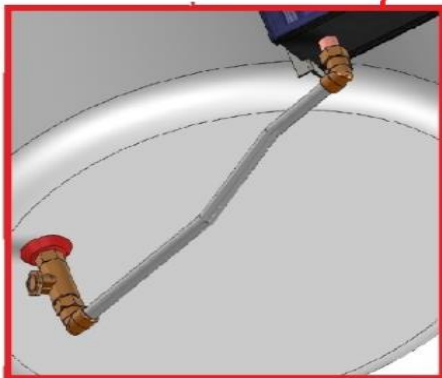

Zigzag shape tube for:  
150-1-S230, 200-1-S230

Important Note: There is no need for E1 part for 1-collector systems

Solar Circuit Lower Pipe (Glycol)

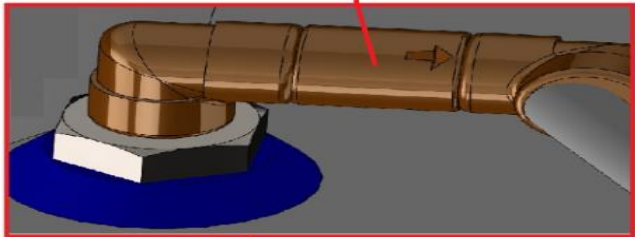

Non Return Valve.  
The arrow must be oriented down.

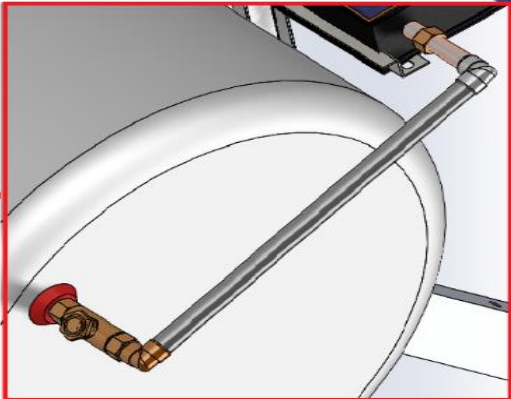
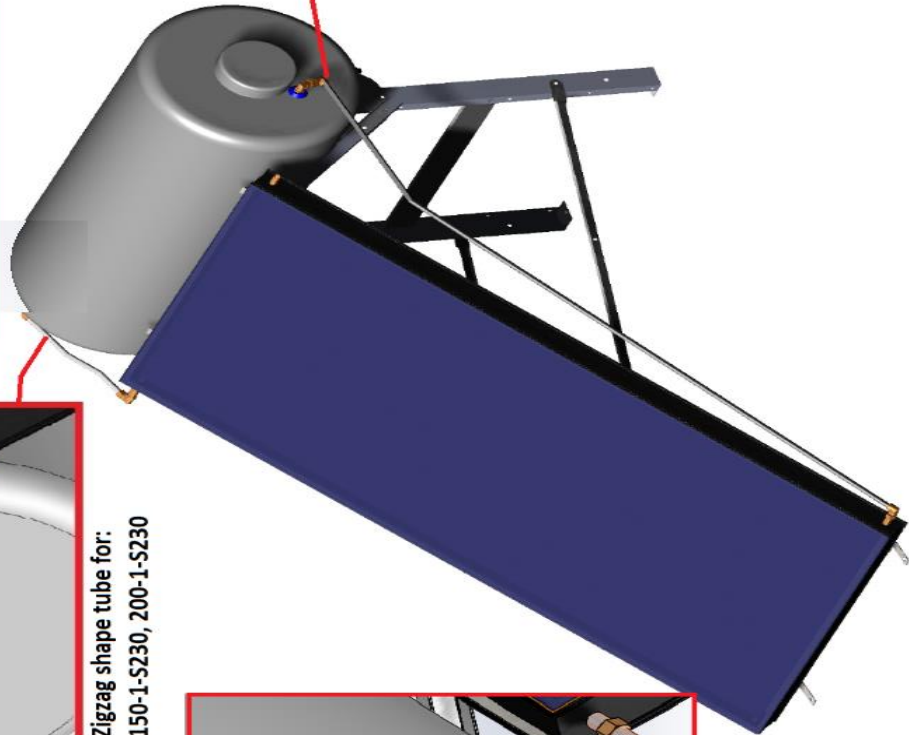

Curved shape tube for:  
150-1-S200, 200-1-S200

C) 2- Collectors System (300-2-S200) Parts

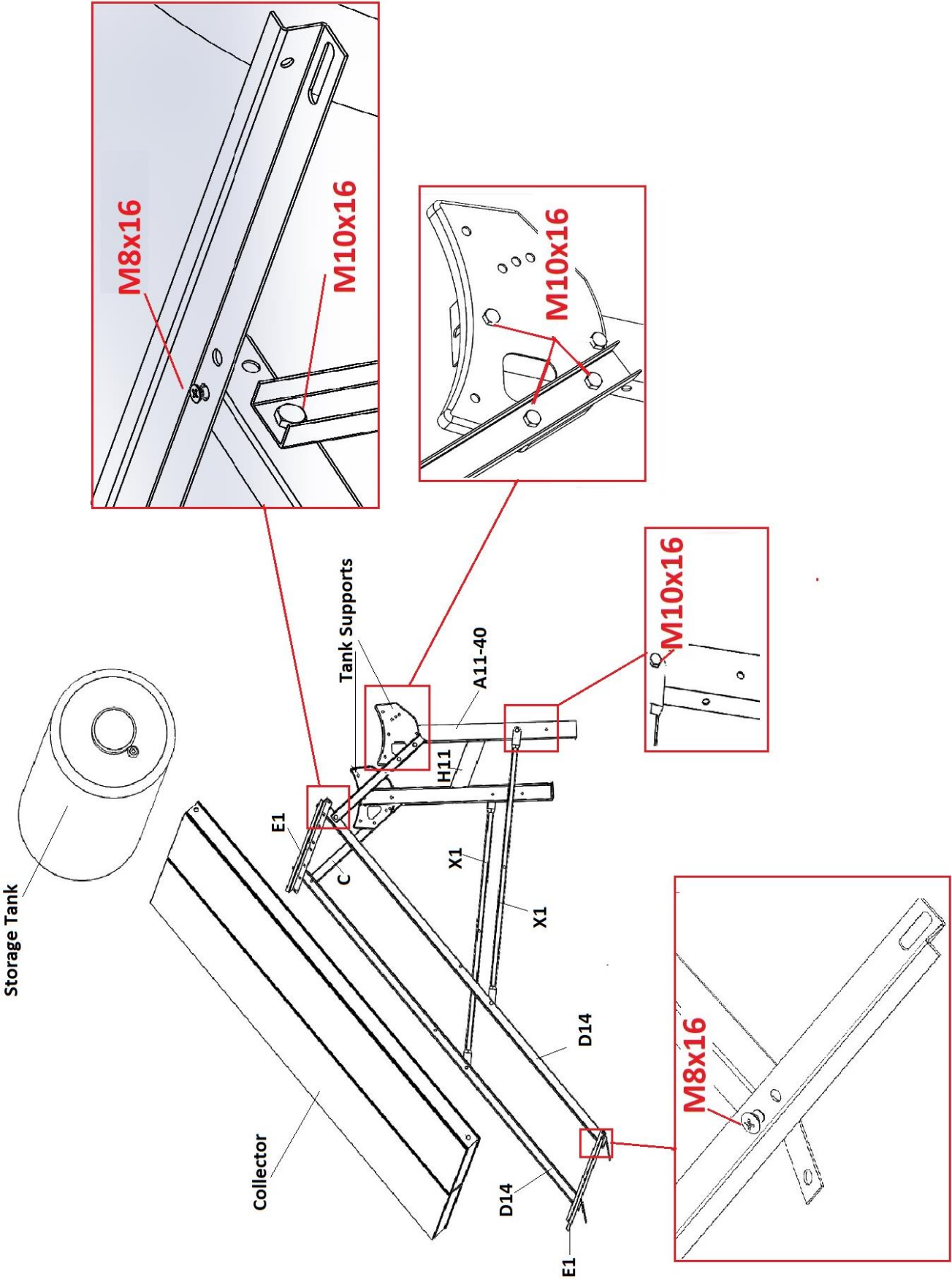

D) 2- Collectors System (300-2-S200) Piping

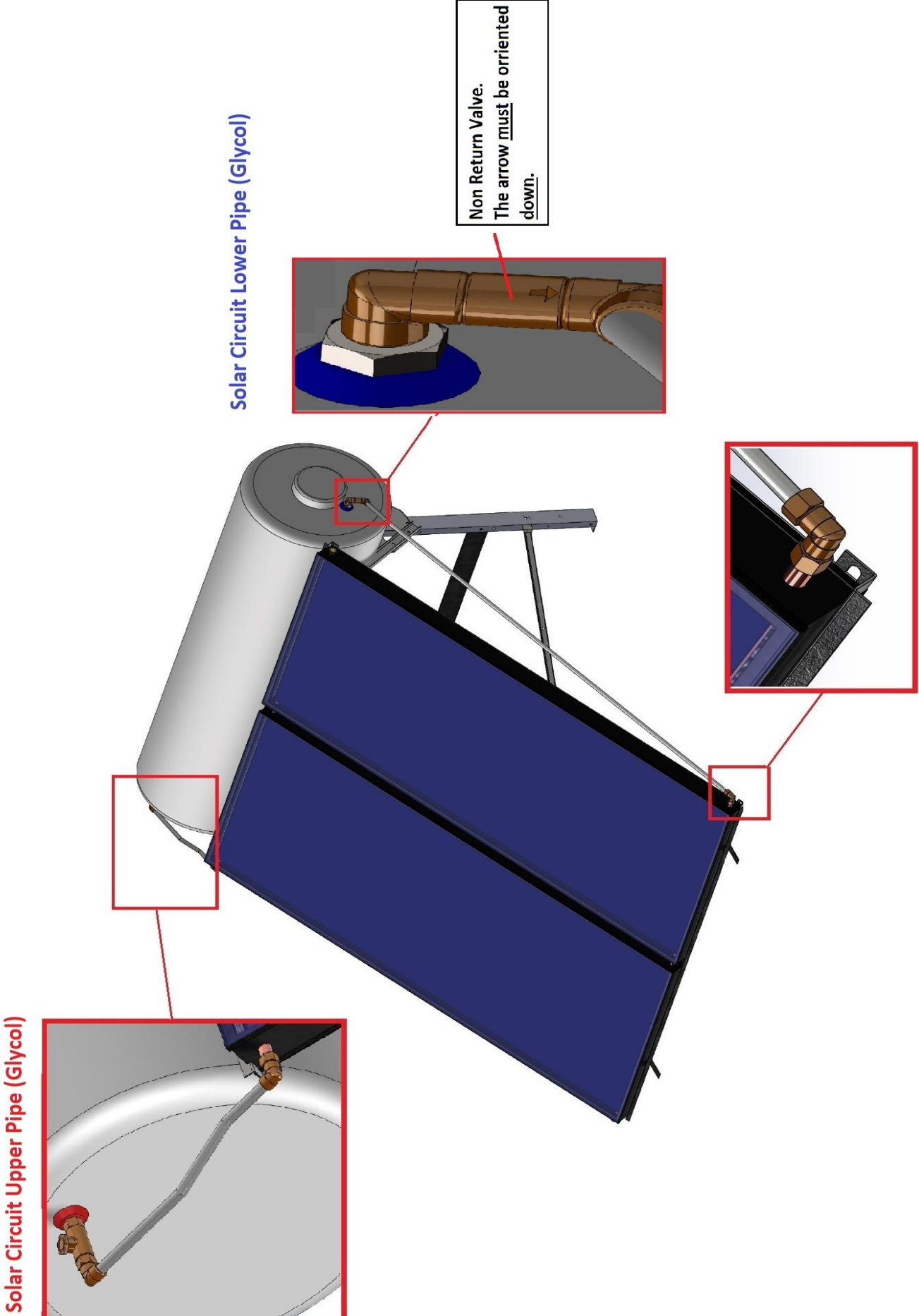



**Published: October 2019, version 5**

**SOLE S.A.**  
**SOLAR DOMESTIC APPLIANCES MANUFACTURER**  
**Lefktron & Laikon Agonon, 136 71 Acharnai – Athens – Greece**  
**Tel.: (+30210) 2389500 • Fax: (30210) 2389502**  
**Email: [export@sole.gr](mailto:export@sole.gr)      [www.eurostar-solar.com](http://www.eurostar-solar.com)**